

DRAFT 06.21.2021

PART 3.23.00 - WIMAUMA DOWNTOWN - OVERLAY DISTRICT

Section 3.23.01. – Purpose

The purpose of this Part is to establish standards for the Wimauma Downtown (WD) Overlay District. The overlay district and its design standards implement the vision, principles, and strategies of the Wimauma Community Plan, as found in the Future of Hillsborough Comprehensive Plan.

The intent of these regulations is to improve and encourage the vitality and development of Wimauma's center and Main Street along State Road 674, and establish a mixed use, walkable, and pedestrian friendly downtown district with small town character. All development shall be in accordance with the standards for development as described in this Part and as appropriate.

Section 3.23.02. – Applicability

- A. Except as provided herein, these standards shall apply to all new development on parcels within and to all development aggregated with development within the WD Overlay District area as of March 1, 2021. The WD Overlay District is as shown in Figure 1.
 1. These provisions shall not apply to public schools and previously approved planned developments, previously approved subdivisions, projects with unexpired building permits, unexpired preliminary site development approval, or unexpired construction plan approval as of October 1, 2021.
 2. In addition to the standards provided herein, development within the WD Overlay District shall be required to meet all other applicable sections of the Land Development Code. Where any provision of these regulations conflict with any other standards or regulations of the Land Development Code, these regulations shall prevail.
 3. Minor and major modifications to pre-existing Planned Developments within the applicable area shall be evaluated for consistency with these regulations and shall comply to the greatest extent possible. In applications where only a portion of the pre-existing Planned Development is proposed for minor or major modification, these regulations shall only apply to the portion of the project subject to the modification.
 4. Legally established single-family dwellings (conventional or manufactured), two-family dwellings and multi-family dwellings, in existence at the time of the adoption of this overlay, may be replaced, renovated and/or enlarged in accordance with the subject property's zoning district standards and applicable building codes. These overlay provisions are voluntary and shall not make such uses nonconforming. Additionally, these regulations are voluntary to any non-conforming residential use determined to be legally nonconforming before or after the adoption of this overlay under Land Development Code Section 11.03.06
 5. Legally established mobile home parks in the Urban Service Area, in existence at the time of the adoption of this overlay, are not subject to these provisions. These provisions are voluntary and shall not make such uses nonconforming.
- B. The following requirements shall apply to all building activity within the Wimauma Downtown Overlay District, subject to the applicability provisions in Section 3.23.02.A above. The applicant shall be responsible for providing the necessary information to determine the applicable sections of this Part, as listed below and in Table 1. All new signs shall comply with the limitations and provisions of Article VII of this Code and with Section 3.23.13 of this Part.
 1. For all projects requiring building permits where structures are expanded to between 25 and 50 percent of existing legally permitted square footage within the parcel, the landscaping and

DRAFT 06.21.2021

signage requirements of this Part shall apply.

2. For all projects requiring building permits where structures are expanded to beyond 50 percent of existing legally permitted square footage within the parcel, the landscaping, screening, signage, and building design requirements of this Part shall apply.

3. For all projects where new structures are constructed on a vacant parcel or where a primary structure is replaced by a new structure, the entire requirements of this Part shall apply to the entire project and parcel(s).

4. For all projects where new buildings are placed on a parcel occupied by existing buildings, the landscaping, screening, and signage requirements of this Part shall apply to the entire project and parcels(s), and the General District Development Standards in Section 3.23.04 shall apply to the new construction.

5. Projects increasing the outside area devoted to sales, storage, displays, demonstrations, or parking by more than 50 percent and requiring a building permit shall be considered a major change and shall be required to comply with the landscaping and signage requirements of this Part.

Section 3.23.03. - Permitted Uses

Uses shall be regulated by the underlying zoning of the development parcel as provided in this Code.

Section 3.23.04. - General District Development Standards

The applicant shall be responsible for providing the necessary information to determine compliance with the applicable sections of this Part and Table 5-2. Any unknown conflicts between the overlay and zoning district development standards, the Overlay shall apply. Any uses mentioned in subdistricts will require rezoning.

Commercial locational criteria do not apply to non-residential-uses located within the “Wimauma Downtown Main Street Core” as shown on Figure 1.

1. Wimauma Downtown Districts

A. Main Street Core

Context: Development is most intense in the Main Street Core. Buildings are built along the front property line, creating a continuous street façade to increase walkability. Commercial and civic uses are anticipated in the Main Street Core; a mix of apartments and live/work buildings constitute the residential component of the Main Street Core within walking distance of surrounding residential areas of the Wimauma Village. Refer to Figure 1.

1. The Main Street Core is focused on Main Street. The goal is to provide a consistent downtown streetscape of retail and services that is vibrant and scaled to pedestrians.

- Residential uses encouraged on 2nd or 3rd floor, above other uses
- Office uses encouraged on 2nd floor, above other uses
- Highest density and intensity within the Wimauma Downtown Overlay District
- Serve as the priority receiving zone for Transfer of Development Rights in the Wimauma Village Plan area.
- Within the Wimauma Downtown TDR Receiving Zone

DRAFT 06.21.2021

B. Downtown Center

Context: The Downtown Center encourages a range of uses, which should be compact and contain both attached and detached buildings. The residential character hosts a mix of housing types including single family attached and detached homes and multi-family units. Homes located in the Downtown Center zone are normally set back from the front property line to allow a front yard with a porch or stoop; lots often have private rear yards. Refer to Figure 1.

1. The Downtown Center encourages higher density residential with some retail services and office uses. This functions as a transition between Downtown Residential and suburban residential neighborhoods, and Main Street uses.

- Live-work units and mixed-use buildings are encouraged.
- Includes the Wimauma Downtown TDR Receiving Zone.

C. Government District

Context: The Government District at Post Office Square is a special district within the Downtown Center adjacent to the Main Street Core. The character is consistent with the Downtown Center but is focused on institutional uses. Refer to Figure 1.

1. Government District at Post Office Square is a special district intended for government and institutional uses, so that they are centrally located in close proximity.

- Concentrates government services close to each other
- Other uses are encouraged to prevent vacant areas and maintain a mix of uses
- Regulations permit flexibility in design for public service buildings to meet community needs.
- Uses such as libraries and government offices, nongovernment institutional including private institutional uses, such as hospitals, clinics and colleges are encouraged.

D. Downtown Residential

Context: The Downtown Residential is adjacent to the Downtown Center and within walking distance to the Main Street Core. The Downtown Residential zone is residential in character with a mix of housing types including single family attached and detached homes, live/work units, and some multi-family units. Homes located in the Downtown Residential zone are normally set back from the front property line to allow a front yard with a porch or stoop; lots often have private rear yards. Development should maintain a connected street network. Refer to Figure 1.

- Residential uses are encouraged.
- Multi-family units are encouraged.
- Creates a variety of housing types including single-family attached and detached homes.

E. Wimauma Downtown West

Context: Focusing larger scale uses outside of the compact downtown will allow small business to develop near residential uses within the most pedestrian oriented zones of the district. Refer to Figure 1.

- Uses per the underlying zoning

F. Wimauma Downtown East

Context: Focusing larger scale uses and development outside of the compact downtown while connecting to the adjacent downtown core. Refer to Figure 1.

- Uses per the following list:

DRAFT 06.21.2021

- Agricultural manufacturing, Agricultural packing house, Agricultural stands, Airport related activities, All Office & Professional Services Uses, Ambulance Services, Animal hospital/veterinary clinic – large & small, Assembly Plants
- Bicycle repair, Blueprinting, Body shops, Brewery, Building materials lot, Building supply centers and do-it- yourself centers, Bus terminal, Business school, Catering, Commercial school, Contractor’s office without open storage
- Electric/electronic repair large & small, Equipment rental & leasing – light, Equipment storage yards, Exterminator, Farm & garden supply centers, Farm & garden equipment sales and service, Farm equipment sales and service, Furniture refinishing, repair, upholstery & manufacture
- Governmental offices, Heliport, Helistop, Hospital & medical centers, Industrial laundry, Kennels, Landscaping contractor nursery, Lawn care & landscaping, Life care treatment center, Lumber/building mate
- Mail and package services, Mail order office, Mail order pickup facilities, Manufacturing, Mini warehouses, Mortuaries, Motor repair – small, Motor vehicle repair – major & minor, Office equipment sales
- Packaging, Packing house, Parks with picnic areas, Plant farm, Printing services, Processing, Radio or TV broadcasting studios, Repair shops, Sales, rental & service of new or used domestic vehicles, farm & garden equipment & private pleasure crafts
- Sign painting, Stables – public or private, Storage yards for equipment, machinery & supplies for building & trade contractors, Train terminal, Truck stop, Trucking & truck terminal, Vocational school, Wholesale distribution

2. Main Street Core, Downtown Center, Government District, Downtown Residential, Wimauma Downtown East, and Wimauma Downtown West illustrated on District Regulating Plan (Figure 1):

Figure 1

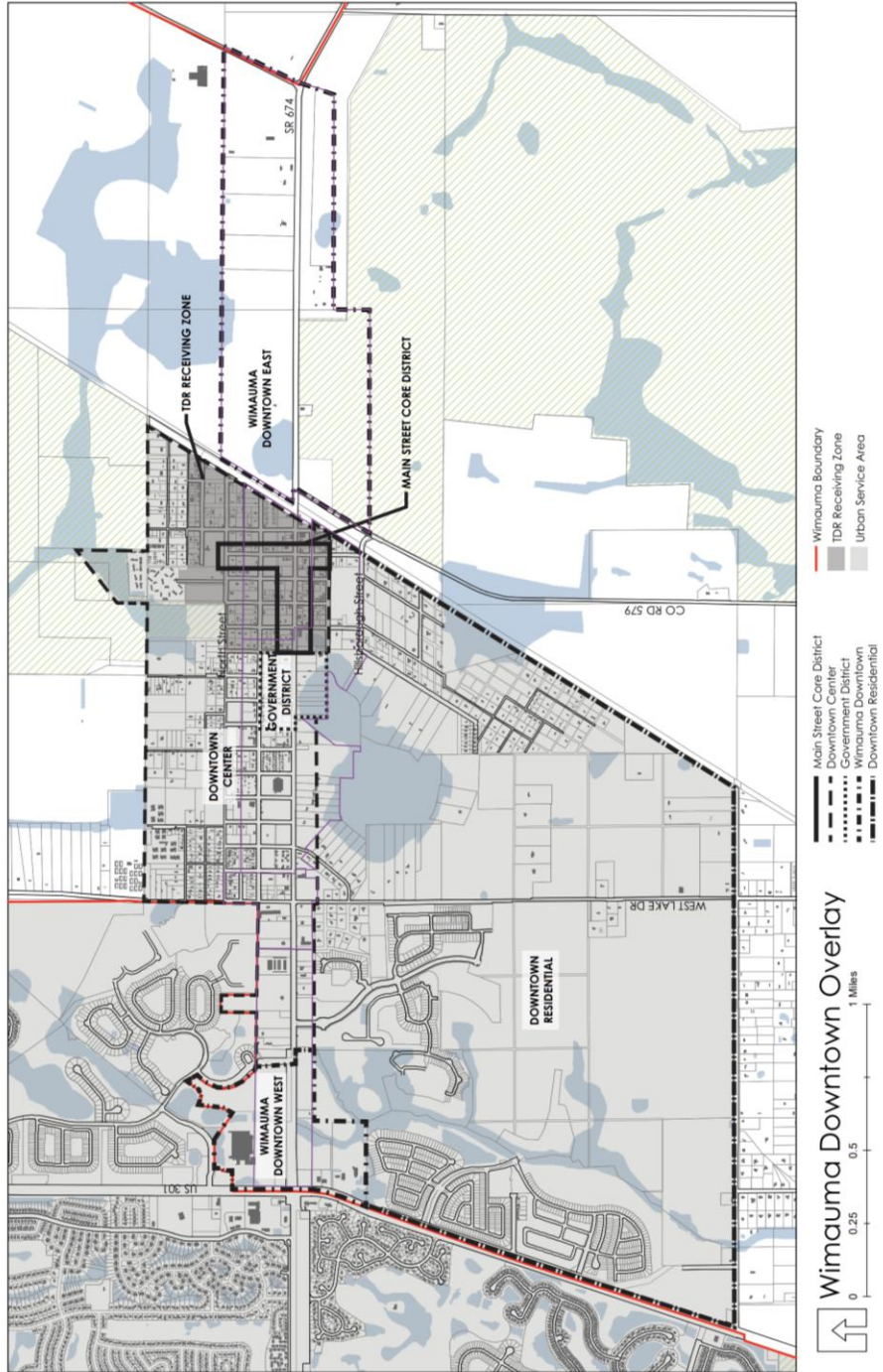

DRAFT 06.21.2021

Section 3.23.05. - Permitted Lot types in the Main Street Core, Downtown Center, Government District, and Downtown Residential districts:

The following lot types in Table 5-1 shall be assigned within the corresponding districts as shown in the following matrix. An applicant may propose additional lot types during a rezoning process provided the lot types comply with the intent of the Wimauma Downtown Overlay.

Lot Types	Main Street Core	Downtown Center	Downtown Residential	Government District	Village Residential (WVR-2)
Mixed-Use Building Lot	✓	✓		✓	
Retail Building Lot	✓	✓		✓	
Apartment Building Lot	✓	✓		✓	✓
Live/Work Building Lot	✓	✓		✓	✓
Apartment House Lot	✓	✓	✓	✓	✓
Courtyard Apartment Lot	✓	✓	✓	✓	✓
Rowhouse Building Lot	✓	✓		✓	✓
Sideyard House Lot		✓	✓		✓
Cottage House Lot		✓	✓		✓
Standard House Lot	✓	✓	✓	✓	✓
Civic Building Lot	✓	✓	✓	✓	✓

* Apartment House and Courtyard Apartment Lots within the Downtown Residential will only be encouraged in appropriate locations.

Table 5-1

1. Table 5-2 provides percentage of coverage requirements that apply to all lots of each designated type.
2. If additional lot types are proposed by an applicant, comparable dimensional requirements must also be proposed. An applicant may also propose changes to the coverage requirements in Table 5-2 for a particular lot type.
3. All lot types permitted in the Downtown Center are permitted in Wimauma Downtown West.

DRAFT 06.21.2021

Table 5-2 (lot size under review)

LOT TYPE	LOT SIZE (min/max SF)	LOT WIDTH (min/max)	BUILDING FRONTAGE (min/max)	LOT COVERAGE BY BLDG (max)	YARD (min and max)			HEIGHT (min/max in stories; max i feet)
					FRONT(*1)	REAR	SIDE	
					Mixed-Use Building Lot	2,400/98,050	24/no max	
Retail Building Lot	2,400/49,000	24/120	70/100%	80%	0/10	15	0	1/4; 50'
Apartment Building Lot	2,400/98,050	24/no max	70/100%	80%	0/10	15	0	2/4; 50'
Live/Work Building Lot	1,800/11,400	16/60	80/100%	80%	0/10	15	0	2/3; 45'
Apartment House Lot	4,800/25,000	48/130	60/80%	70%	10/15	15	0	1/4; 50'
Courtyard Apartment Lot	4,800/18,000	60/no max	50/80%	70%	10/15	10	0	1/2.5; 35'
Rowhouse Lot	1,800/3,840	16/32	90/100%	80%	0/15	15	0 (*3)	2/3; 35'
Cottage House Lot	2,400/4,800	24/40	70/90%	60%	10/25	10	2	1/2; 30'
Sidyard House Lot	3,000/6,000	30/60	60/90%	50%	10/15	10	0/10 (*2)	1/3; 35'
Standard House Lot	5,000/14,800	50/80	50/70%	40%	20/40	10	5	1/3; 35'
Civic Building Lot	5,000/98,050	50/no max	70/100%	80%	0/20	15	0	1/4; 50'

Table 5-2 Notes:

- (1) Corner lots must meet front yard requirements on both streets.
- (2) Sidyard house requires zero-foot setback on only one side, 10-foot setback on the other side, and no back to back zero foot side.
- (3) Rowhouses shall contain at least 3 attached units.
- (4) Garages are encouraged to be located at the rear of the lot.
- (5) Courtyard Apartment lots and Standard House lots will meet minimum Building Frontage requirement unless lots are located on Main Street.

Sec. 3.23.06. – Standards for Development of Main Street (4th Street) and State Road 674 within the Main Street Core District and Government District.

The applicant shall be responsible for providing the necessary information to determine compliance with the applicable sections of this Part.

1. Building Frontage

Buildings must occupy a minimum of 70% of a parcel's street frontage along Main Street (4th Street) and State Road 674 between State Road 579 and Maggie Street, except when driveways to rear parking access may be impeded by the minimum requirement. Plazas, parks, and patios along Main Street frontage may count toward building frontage

DRAFT 06.21.2021

requirements. Natural resources protected by Part 4.01.00 of this Code shall be excluded from a parcel's street frontage dimension.

2. Main Street Building Setbacks

A. A 10-foot maximum variation in setback along the street frontage is allowed within each project. On parcels containing natural resources protected by Part 4.01.00 of this Code, the building setbacks shall be the minimum possible to avoid said areas.

B. Side and rear yard setbacks shall be in accordance with Table 5-2.

3. Floor Area Ratio

Employment and shopping opportunities are centered in the Wimauma Downtown where existing zoning determine FAR.

4. Building Orientation

A building's primary orientation and façade shall be toward State Road 674, Main Street (4th Street), or other Downtown Center streets rather than the parking areas. The primary building entrance(s) shall be visible and directly accessible from the street. Entrance(s) shall be a distinctive and prominent element of the architectural design. Buildings shall incorporate lighting and changes in mass, surface or finish material, or balcony, porch or awning to emphasize the entrance(s).

5. Building Design

A. Blank walls shall not occupy over 50 percent of a street-facing frontage and shall not exceed 20 linear feet without being interrupted by a window or entry. No more than 20 feet of horizontal distance of wall shall be provided without architectural relief for building walls and frontage walls facing the street.

B. The building façade must be architecturally finished to grade.

C. Buildings are required to incorporate porch-like character including porticos or awnings along street-facing, park-facing, plaza-facing, and patio-facing building façades. These features may be counted toward the architectural relief.

D. New parking shall occur within parking garages or within surface lots that are located behind the line of the building façade. First-story or ground floor individual unit garage access for multi-family or mixed-use structures shall not be permitted to face Main Street or State Road 674.

E. Each building on a Mixed-Use Building Lot, a Retail Building Lot, a Live/Work Building Lot, or a Civic Building Lot must have an entrance facing a street or public open space.

F. For Mixed-Use Building Lots and Retail Building Lots, a portion of the building frontage may be set back up to an additional 20 feet beyond the maximum front yard depth if this space is constructed as a courtyard or entryway that is open to the sidewalk. This portion may be up to 25% of the actual building frontage and may not be used for parking.

G. Each building must have separate walls to support all loads independently of any walls located on an adjacent lot. Buildings with side-facing windows must provide necessary light and air shafts within their own lot without relying on the side yard of an adjacent lot.

H. Each building on a Building Lot is required to have an awning, balcony, colonnade, or arcade facing the street. The same requirement applies to Retail Building Lots except that a porch may be substituted. Buildings on Live/Work Building Lots are encouraged but not required to have one of these features. Any of these features may extend into the front set

DRAFT 06.21.2021

back. When providing a required awning, balcony, colonnade, arcade, or porch, the following design requirements apply:

- a. Awnings over first-floor doors or windows must have a depth of at least 6 feet. Back-lit, high-gloss, or plasticized fabrics are prohibited.
 - b. Balconies must have a depth of at least 5 feet and a clear height below of at least 10 feet from the sidewalk. Balconies may have roofs but must be open and not air-conditioned.
 - c. Colonnades and arcades must have a clear width from column to building face of at least 8 feet and a clear height of at least 10 feet above the sidewalk.
 - d. Porches must be at least 8 feet deep and 16 feet wide. Porches typically have roofs but must be open and not air-conditioned.
- I. Minimum and maximum depths of front yards are shown in Table 5-2.
- J. On all Mixed-Use Building Lots and Retail Building Lots, building walls that face streets are required to have between 15% and 75% of their area in transparent windows. In addition, each retail storefront must comply with the following:
- a. The ground floor must have transparent storefront windows covering no less than 75% of the wall area in order to provide clear views of merchandise in stores and to provide natural surveillance of exterior street spaces.
 - b. Storefronts must remain unshuttered at night to provide views of display spaces and are encouraged to remain lit from within until 10:00 PM to provide security to pedestrians.
 - c. Doors allowing public access to streets must be provided at intervals of at least 75 feet to maximize street activity, to provide pedestrians with frequent opportunities to enter and exit buildings, and to minimize any expanses of inactive wall. To be considered transparent, window and door glass, whether integrally tinted or with applied film, must transmit at least 50% of visible daylight. These requirements do not apply to walls that face alleys or lanes.

Section 3.23.07. - Building Form and Placement on Lots for the Main Street Core, Downtown Center, Government District, and Downtown Residential:

The primary entrance of every building must directly face a street, a square, a park, a plaza, or a green. The proper building placement is illustrated below for each lot type

- Mixed-Use Building
- Retail Building
- Apartment Building
- Live/Work Building
- Apartment House
- Courtyard Apartment Building
- Rowhouse
- Cottage House
- Side Yard
- House
- Civic Building

DRAFT 06.21.2021

1. Front loaded garages must be setback 5 feet from the front façade of the main structure. Alley access garages are strongly encouraged.
2. Accessory Structures shall follow the primary building setback in Table 6-1 and not exceed two stories
3. Accessory Dwellings may accommodate up to one dwelling unit.
4. Detached garages shall follow accessory structure setback requirements in Table 6-1 except for the Standard Building Lot where garages may be setback 5 feet from the property line.
5. In yards with required build-to lines for 0' side yard, the entire length of each building façade containing enclosed floor space shall be placed on the build-to line or, on parcels with curved or irregular build-to lines, the chord of the build-to line. Doorways and minor architectural features, such as transoms, sidelights and porticos, recessed into the façade shall be permitted. A maximum of one foot of relief from the build line shall be permitted for architectural features such as cornices and expression lines.
6. Conceptual illustrations below demonstrate lot size and dimensional requirements of Table 5-2.

DRAFT 06.21.2021

1. Mixed-Use Building (MU)

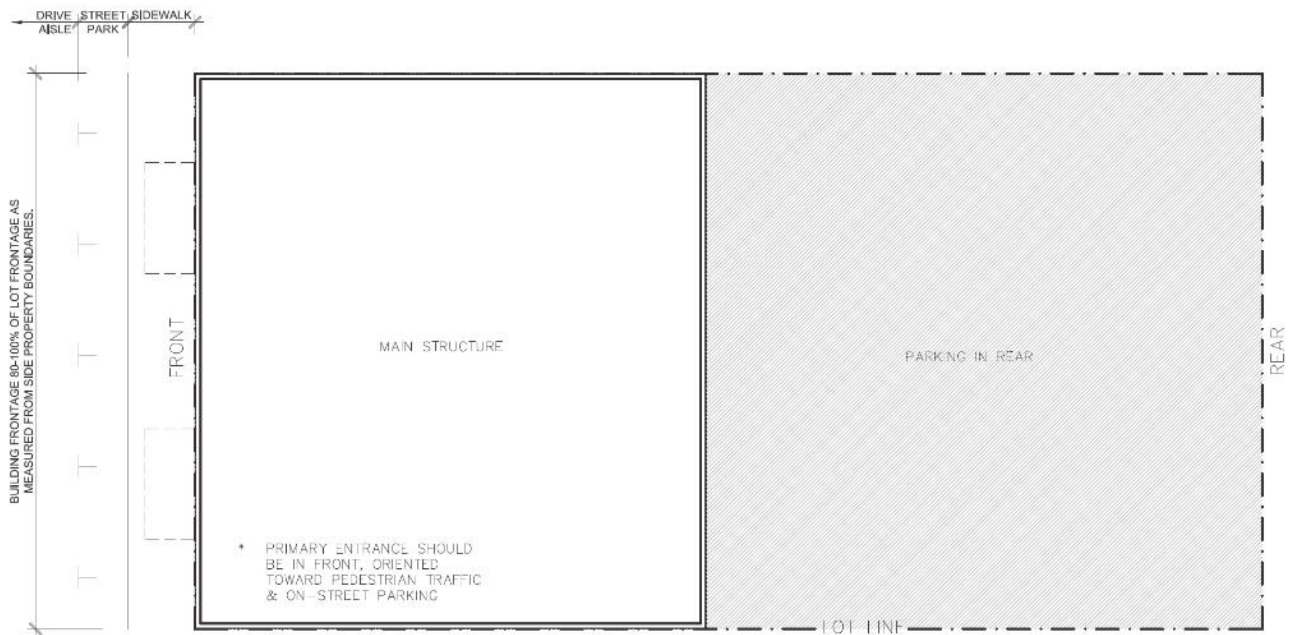
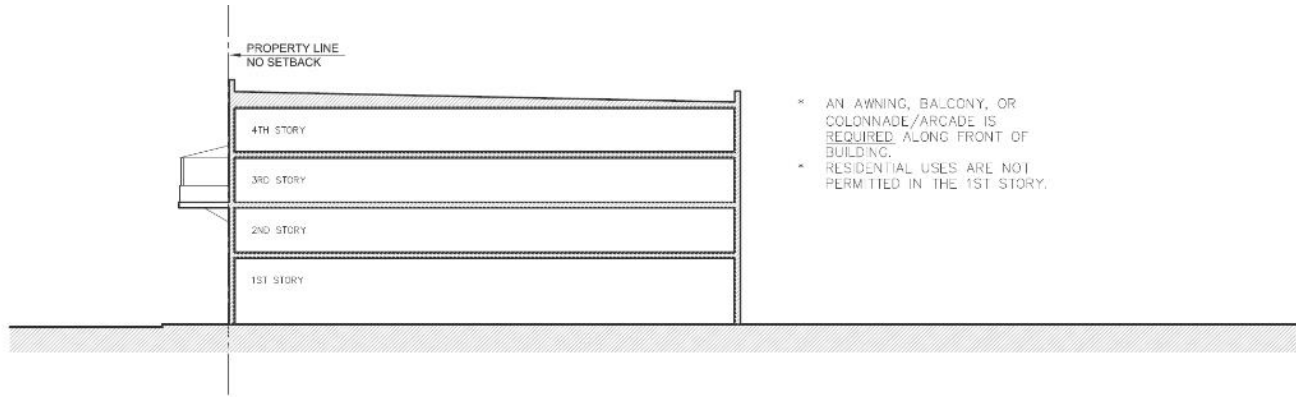

BUILDING PLACEMENT

Off-street parking for Mixed Use Building lots shall be located behind or to the side of the main structure(s). No parking shall be located between the primary façade, or façade portion, closest to the street, and the street.

The building's primary orientation shall be toward the street rather than the parking areas. The primary building entrances shall be visible and directly accessible from a street.

DRAFT 06.21.2021

2. Retail Building (RB)

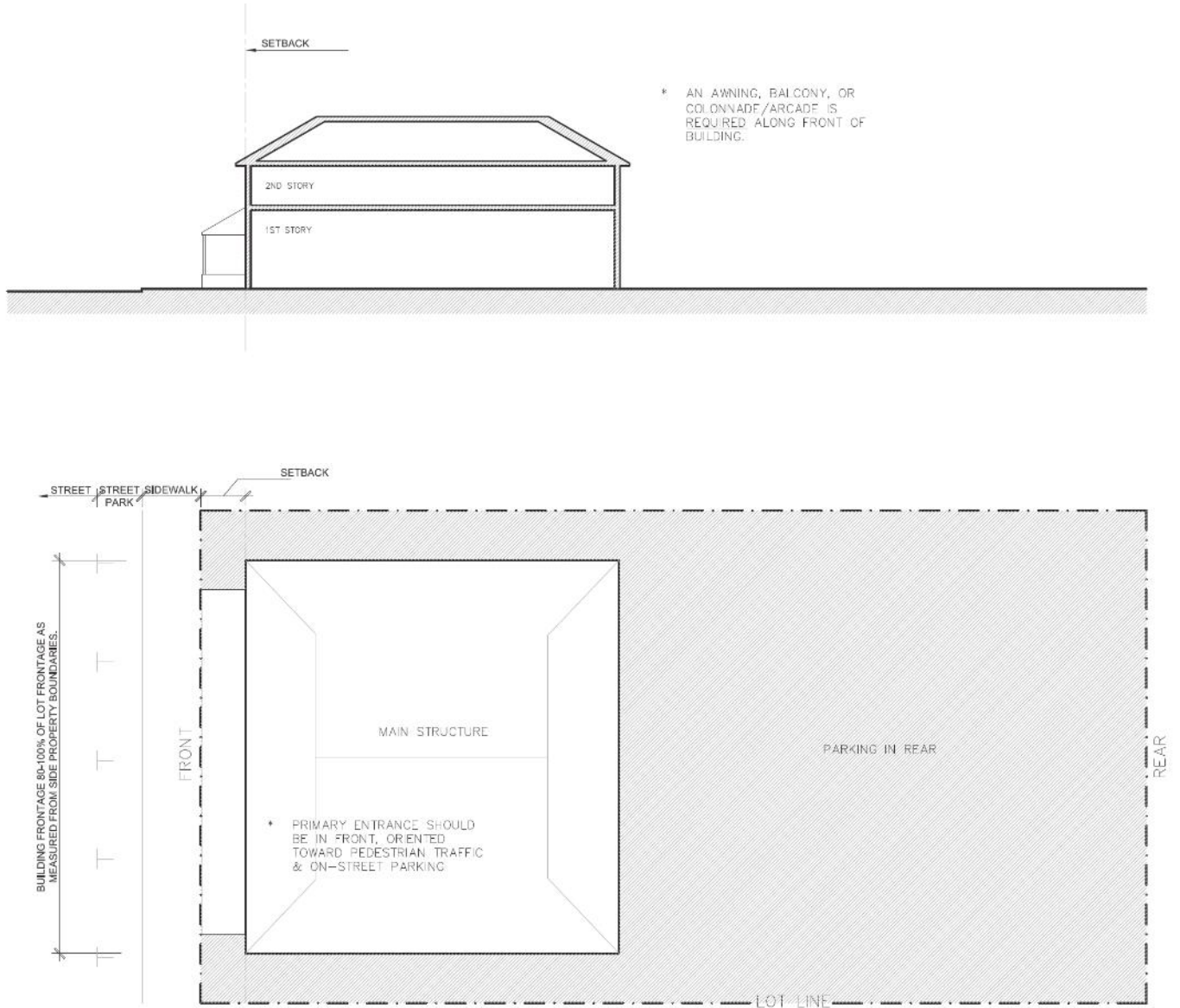

BUILDING PLACEMENT

Off-street parking for Retail Building lots shall be located behind or to the side of the main structure(s). No parking shall be located between the primary façade, or façade portion, closest to the street, and the street.

The building's primary orientation shall be toward the street rather than the parking areas. The primary building entrances shall be visible and directly accessible from a street.

3. Apartment Building (AB)

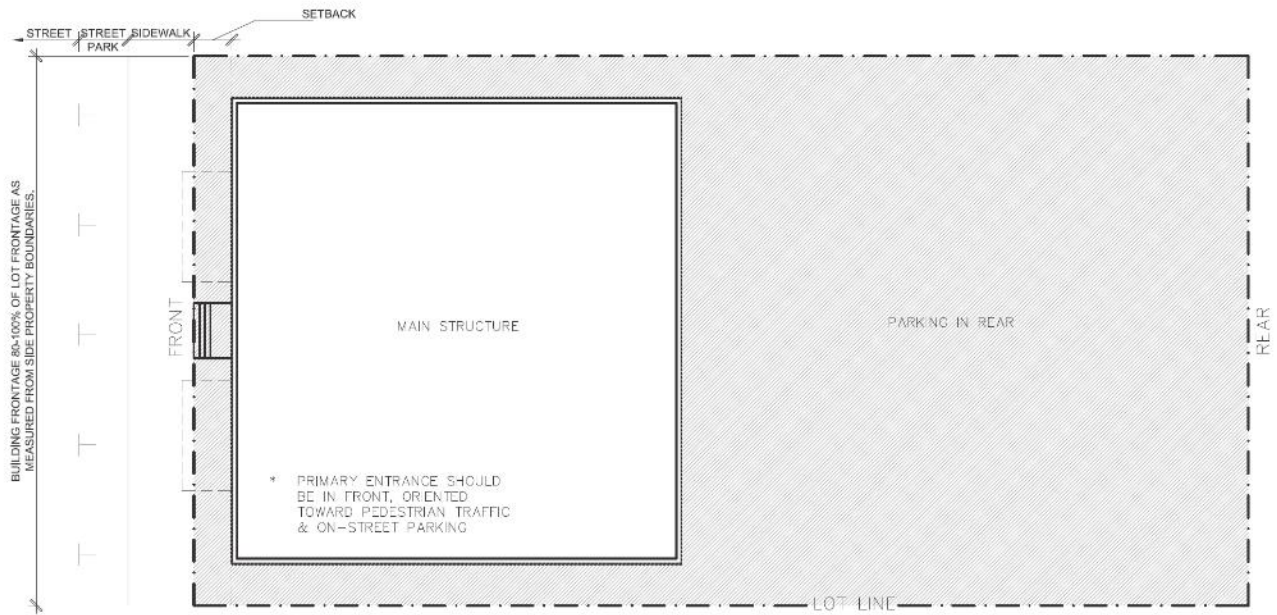
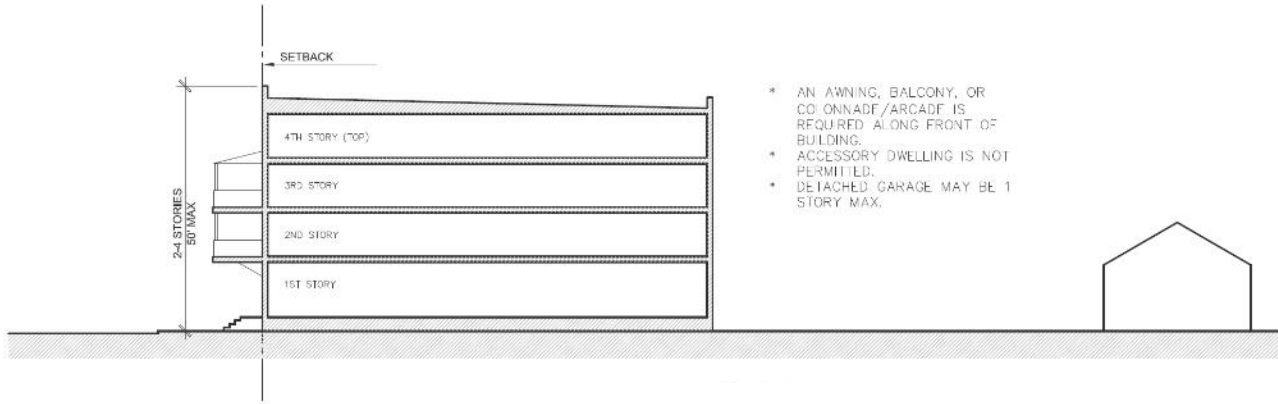

BUILDING PLACEMENT

Off-street parking for Apartment Building lots shall be located behind or to the side of the main structure(s). No parking shall be located between the primary façade, or façade portion, closest to the street, and the street.

The building's primary orientation shall be toward the street rather than the parking areas. The primary building entrances shall be visible and directly accessible from a street.

4. Live/Work Building (LW)

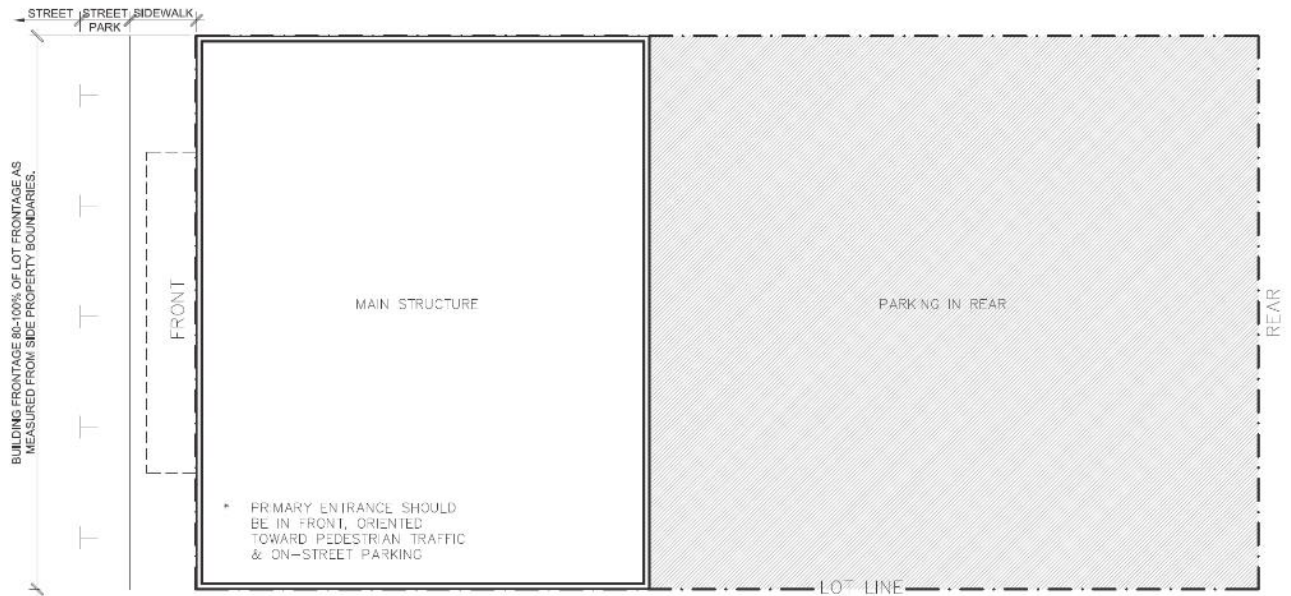
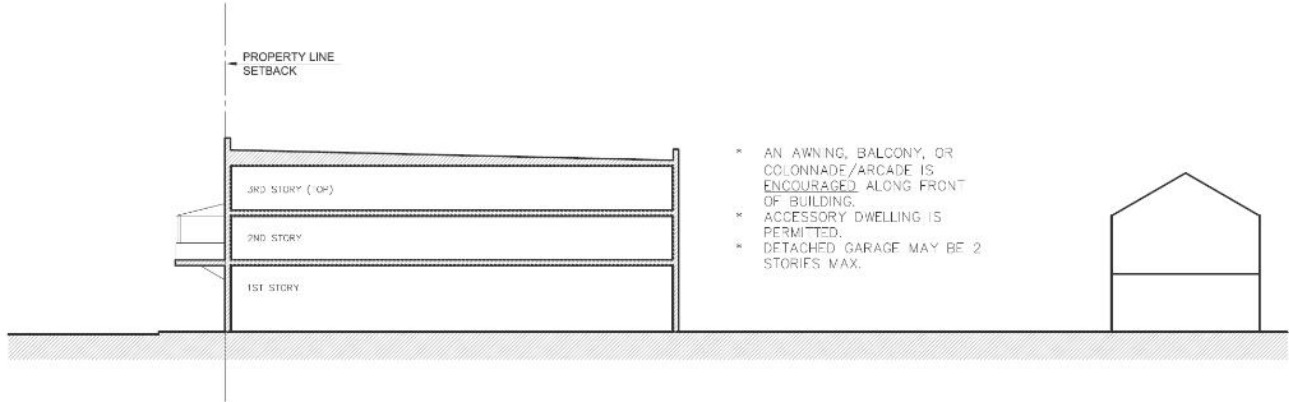

BUILDING PLACEMENT

Off-street parking for Live/Work Building lots shall be located behind or to the side of the main structure(s). No parking shall be located between the primary façade, or façade portion, closest to the street, and the street.

The building's primary orientation shall be toward the street rather than the parking areas. The primary building entrances shall be visible and directly accessible from a street.

DRAFT 06.21.2021

5. Apartment House (AH)

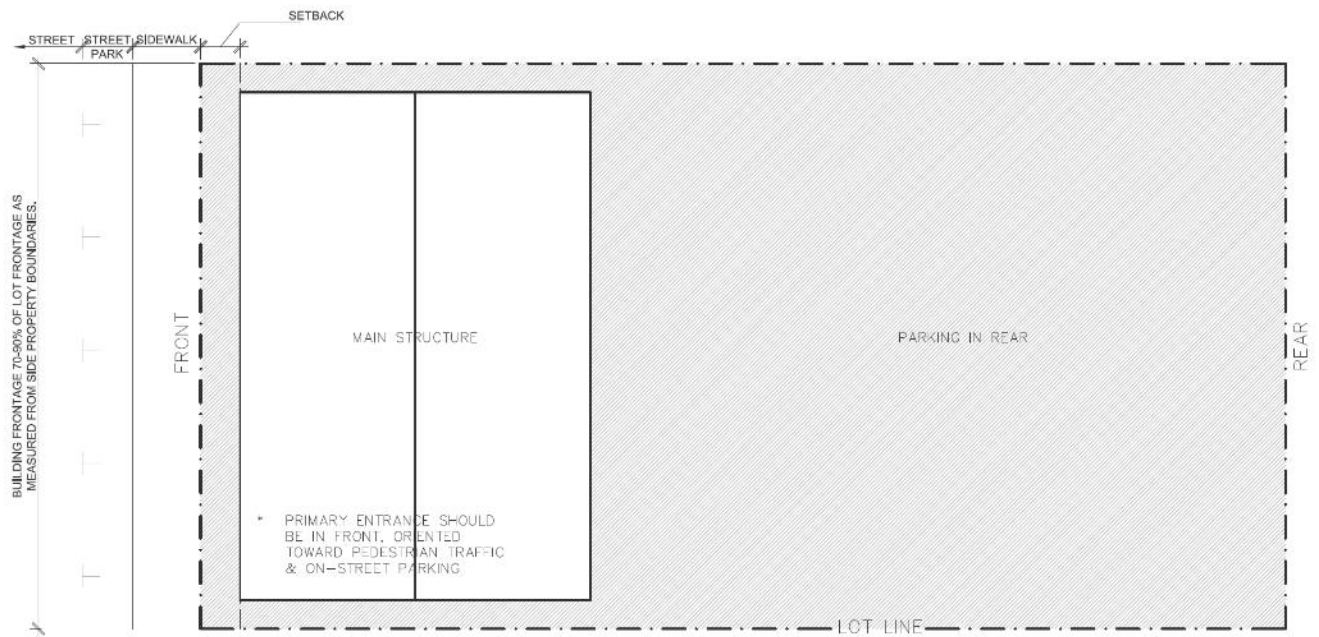
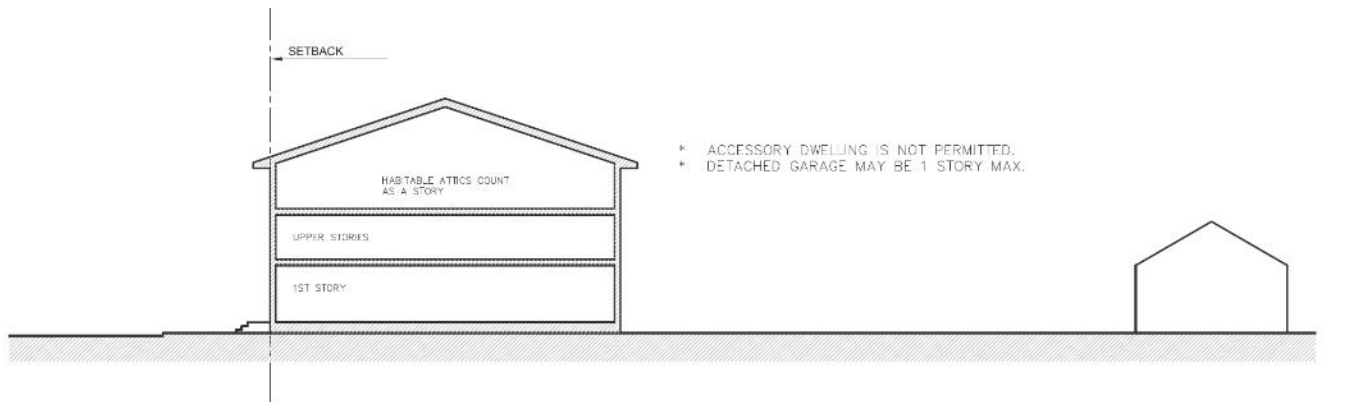

BUILDING PLACEMENT

Off-street parking for Apartment House lots shall be located behind or to the side of the main structure(s). No parking shall be located between the primary façade, or façade portion, closest to the street, and the street.

The building's primary orientation shall be toward the street rather than the parking areas. The primary building entrances shall be visible and directly accessible from a street.

DRAFT 06.21.2021

6. Courtyard Apartment (CA)

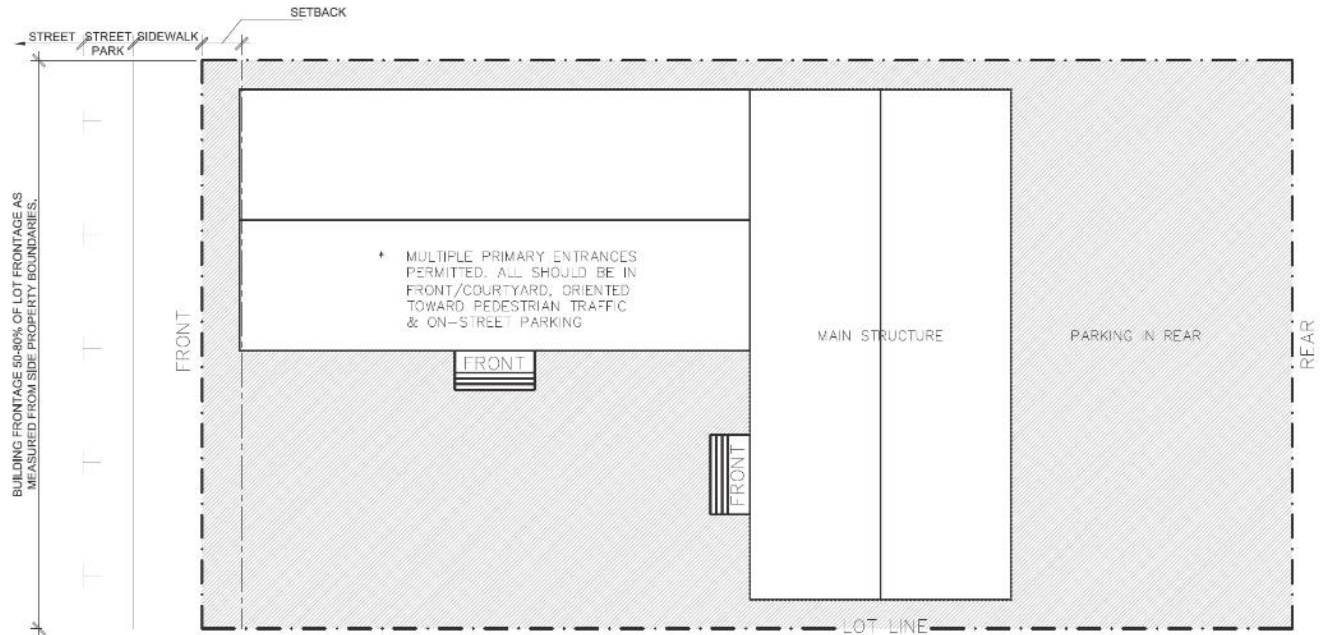
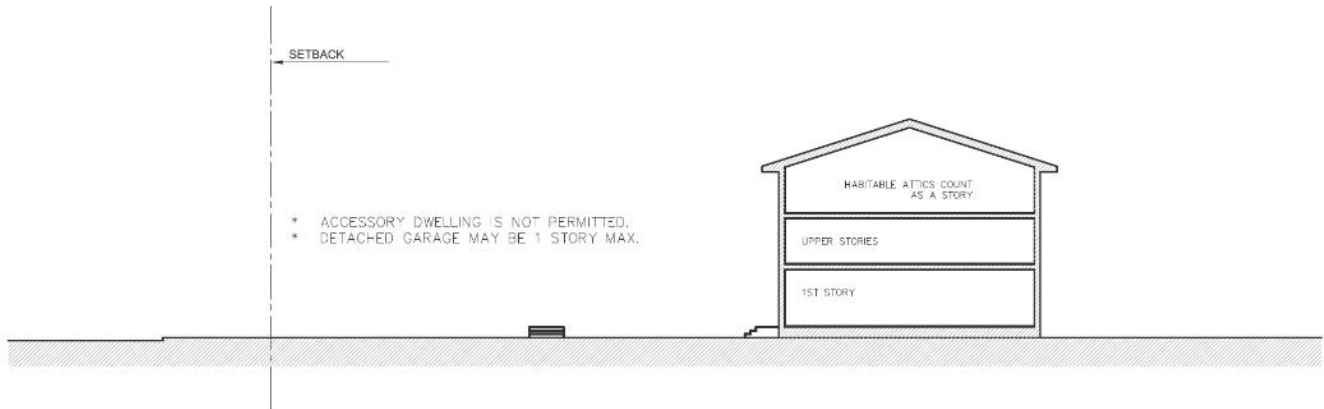

BUILDING PLACEMENT

Off-street parking for Courtyard Apartment lots shall be located behind or to the side of the main structure(s). No parking shall be located between the primary façade, or façade portion, closest to the street, and the street.

The building's primary orientation shall be toward the street rather than the parking areas. The primary building entrances shall be visible and directly accessible from a street.

DRAFT 06.21.2021

7. Rowhouse (RH) or Townhouse

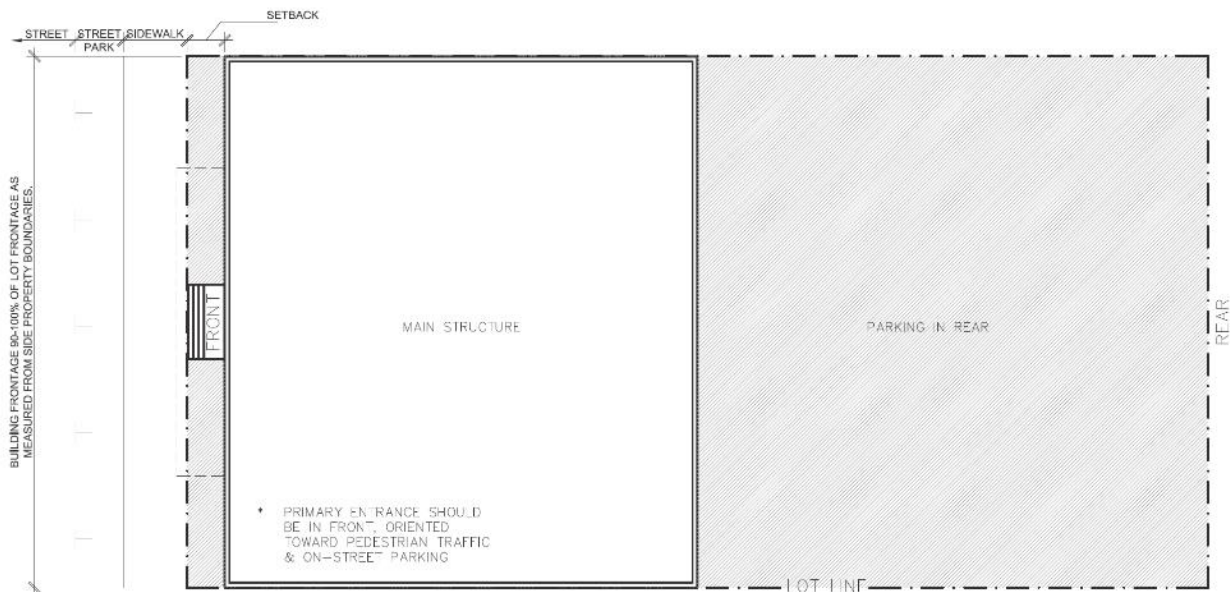
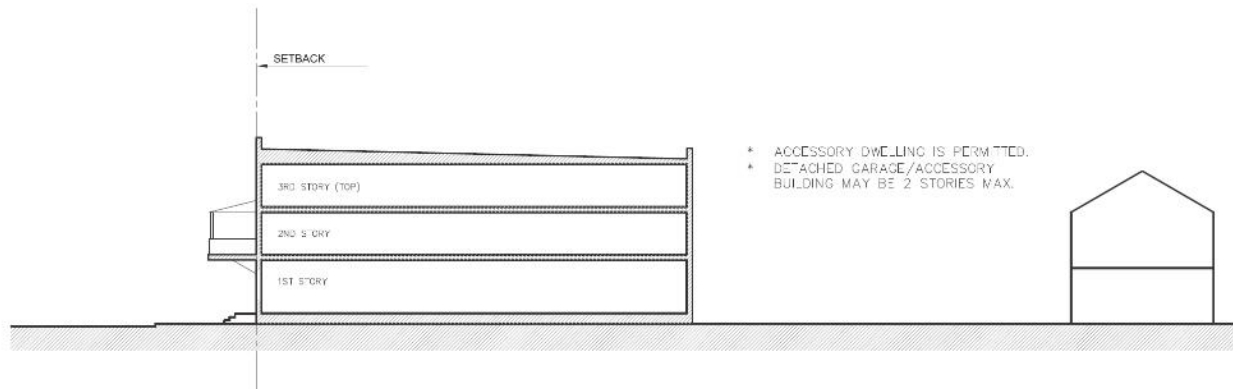

BUILDING PLACEMENT

Attached garages, accessed from the front of the property/street, shall be setback a minimum of 20 feet from the front property line. The remaining residential portion of the structure may be setback at the same distance or at a setback closer to the street. The residential portion shall not be located behind the garage. An offset of at least 10 feet shall be provided between the residential portion and garage portion of the structure when the garage is not flush with the residential facade.

Garages attached to the rear of the rowhouse buildings, accessed from the rear or side of the rowhouse building, are to be accessed via an alley located along the rear of the lot or from the front street via a driveway located to the side of the rowhouse building.

DRAFT 06.21.2021

Detached garages, accessed from the rear or side of the rowhouse building, are to be accessed via an alley located along the rear of the lot or from the front street via a driveway located to the side of the rowhouse building

Should the project provide a parking area, rather than individual garages, the parking area shall be located behind or to the side of the rowhouse building. No parking shall be located between the primary façade, or façade portion, closest to the street.

A building's primary orientation shall be toward the street rather than the parking areas. The primary building entrances shall be visible and directly accessible from a street.

DRAFT 06.21.2021

8. Cottage House (CH)

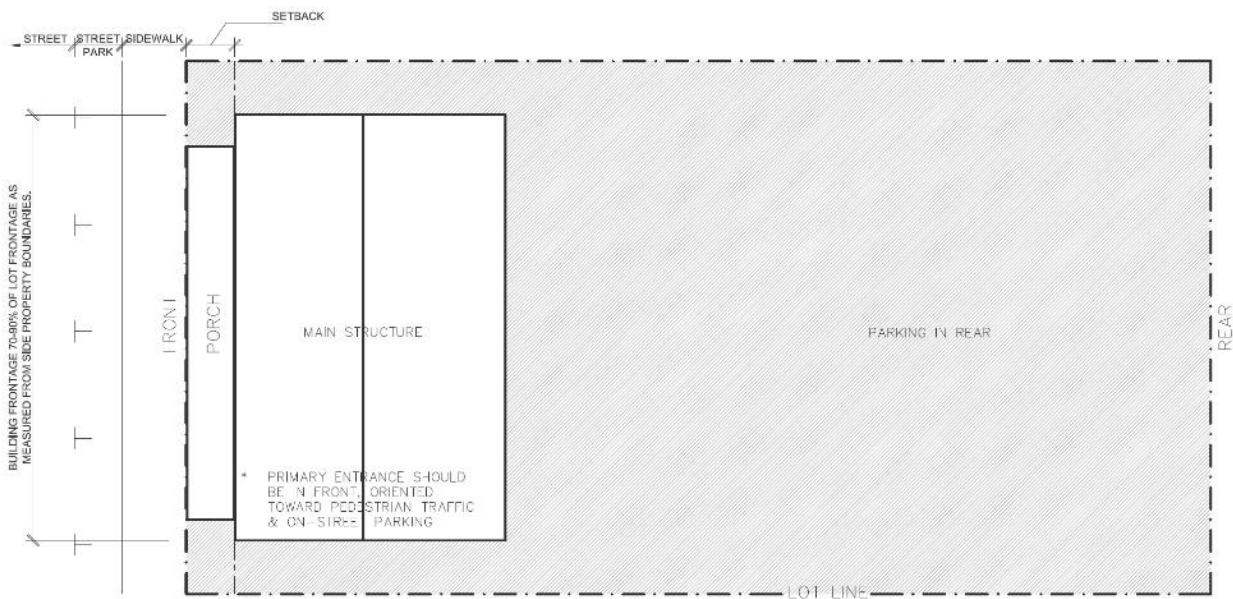
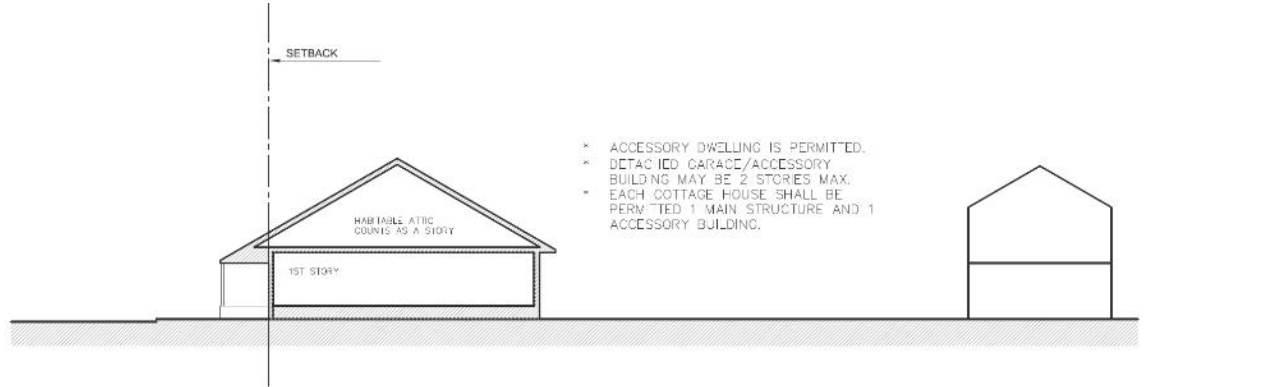

BUILDING PLACEMENT

Each structure shall provide a porch along a minimum of 70% of the façade. The porch shall be used in the building frontage percentage calculation.

On-site parking shall be accommodated with a detached garage, or attached rear-loading garage, to be accessed via an alley located along the rear of the lot or from the street via a driveway located to the side of the home.

DRAFT 06.21.2021

9. Sideyard House (SH)

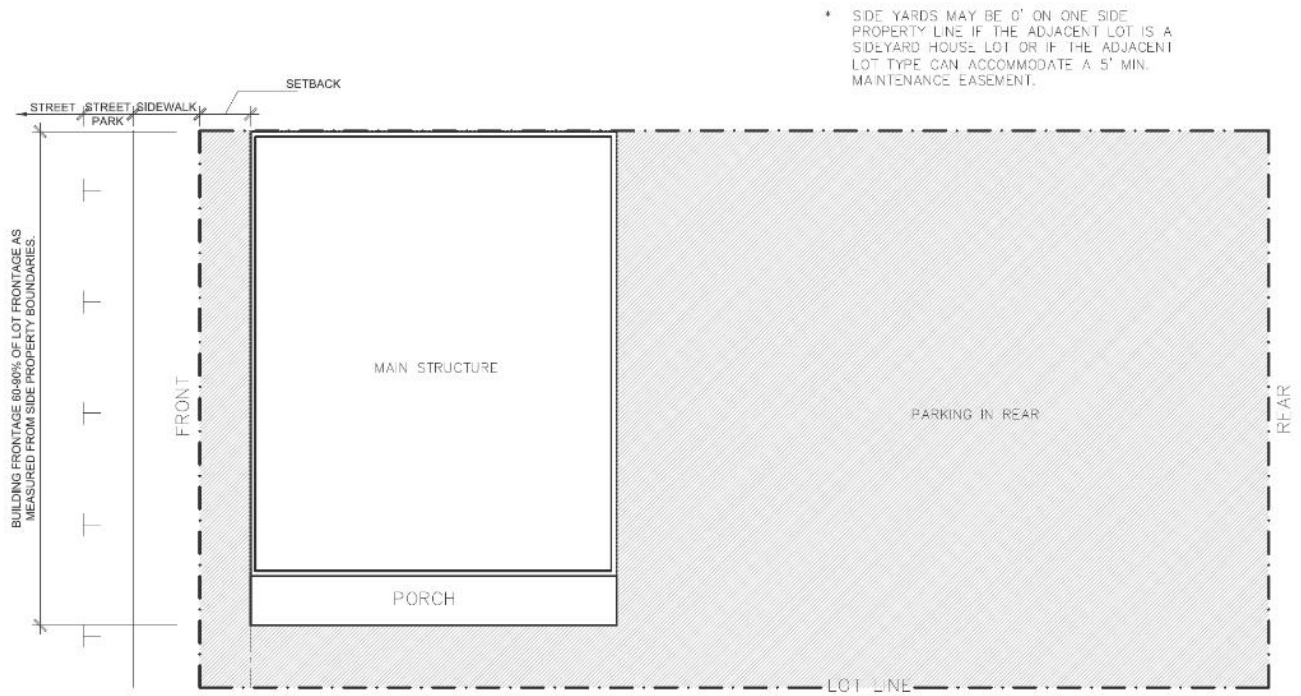
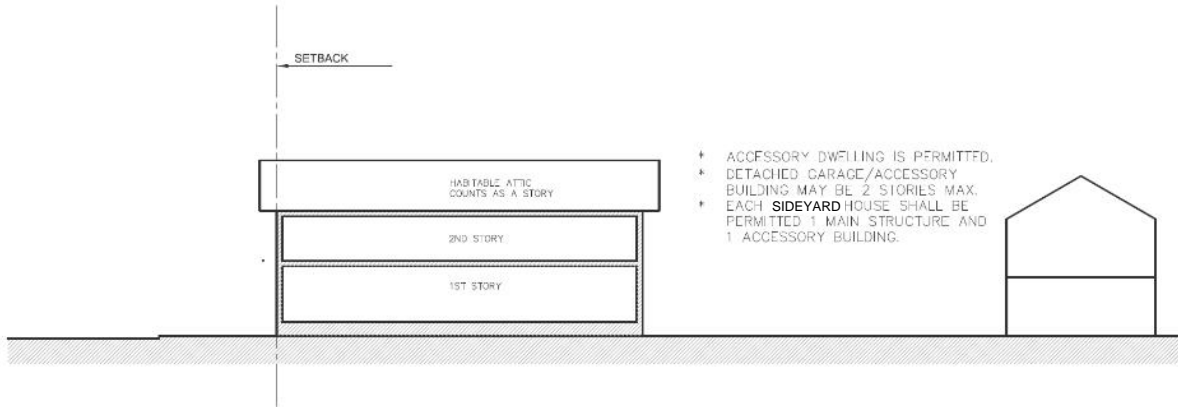

BUILDING PLACEMENT

Each structure shall provide a porch along at least 75% of the side façade not placed at a 0-foot side yard setback.

On-site parking shall be accommodated with a detached garage, or attached rear-loading garage, to be accessed via an alley located along the rear of the lot or from the street via a driveway located to the side of the home.

DRAFT 06.21.2021

10. Standard House (HO)

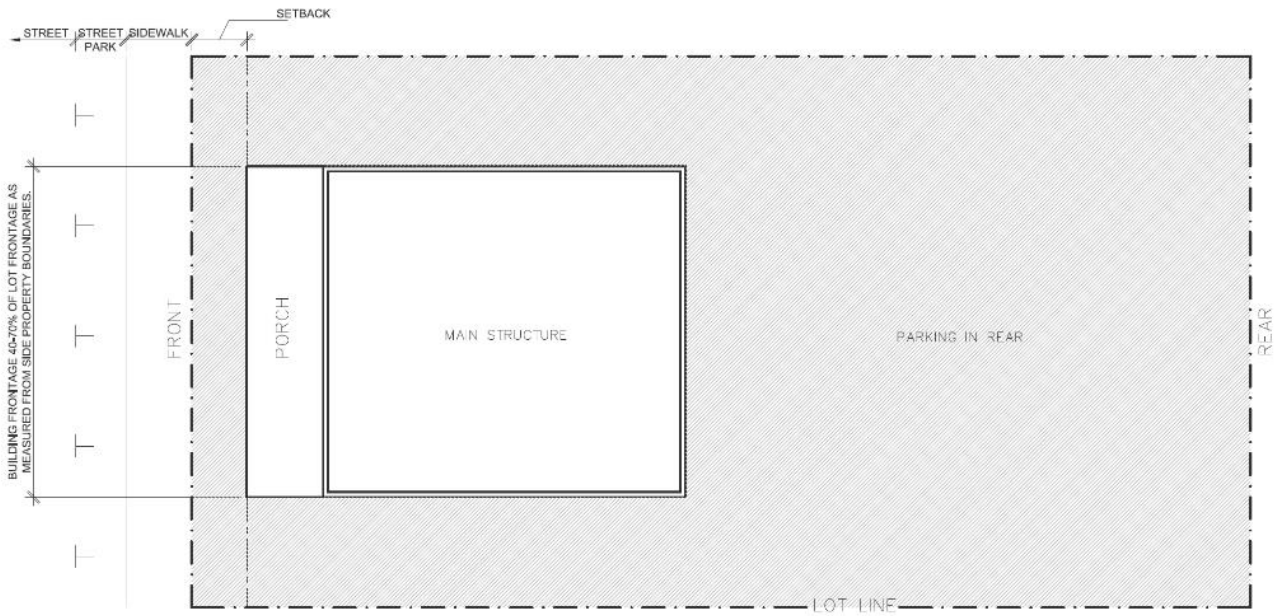
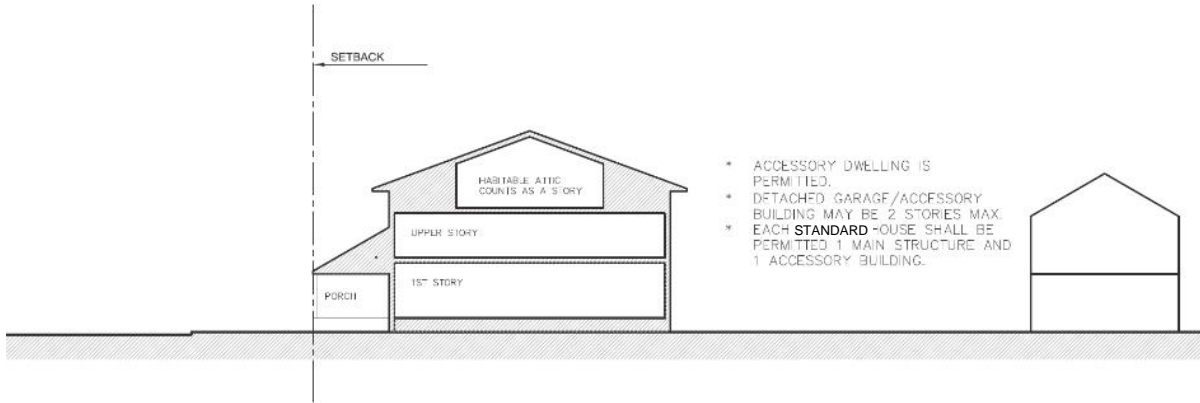

BUILDING PLACEMENT

Each structure shall provide a porch along a minimum of 80% of the façade. The porch shall be used in the building frontage percentage calculation.

Any on-site parking shall be accommodated with a detached garage, or attached rear-loading garage, to be accessed via an alley located along the rear of the lot.

DRAFT 06.21.2021

11. Civic Building (CB)

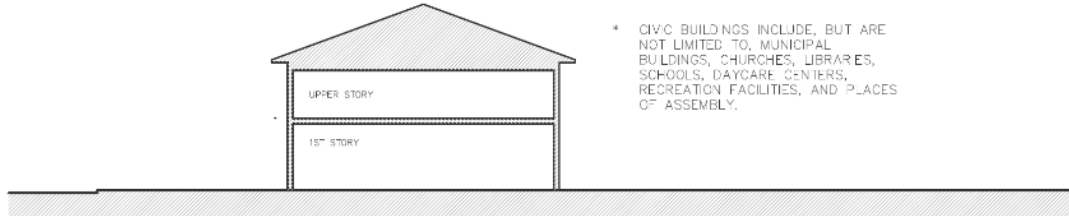

* CIVIC BUILDINGS INCLUDE, BUT ARE NOT LIMITED TO, MUNICIPAL BUILDINGS, CHURCHES, LIBRARIES, SCHOOLS, DAYCARE CENTERS, RECREATION FACILITIES, AND PLACES OF ASSEMBLY.

* BUILDING PLACEMENT REQUIREMENTS FOR CIVIC BUILDINGS VARY BY SITE. IN GENERAL, CIVIC BUILDINGS SHOULD BE SITED IN LOCATIONS OF PARTICULAR GEOMETRIC IMPORTANCE, SUCH AS ANCHORING A MAJOR PUBLIC SPACE, OR TERMINATING A STREET VISTA.

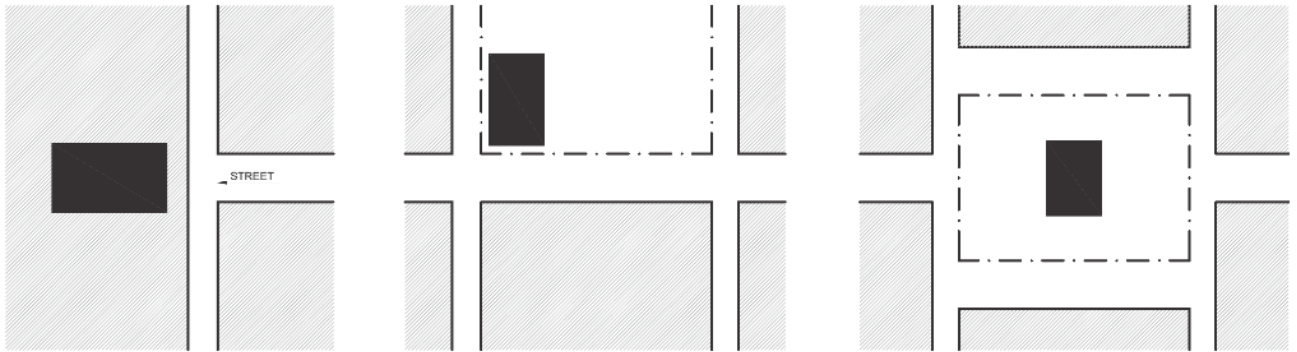

* THE CIVIC BUILDING TERMINATES THE VIEW OF THIS STREET.

* THE CIVIC BUILDING ANCHORS THE GREEN AT A PROMINENT CORNER.

* THE CIVIC BUILDING ANCHORS THE SPACE FROM WITHIN THE GREEN.

Each building on a Civic Building Lot must have an entrance facing a street or public open space. Parking shall be located to the side or rear of the building

DRAFT 06.21.2021

Section 3.23.08. – Allowable Street types for new development and redevelopment in the Main Street Core, Downtown Center, Downtown Residential, Government District, and Wimauma Light Industrial and Commercial

Below designate the following street types with applicable streets in Wimauma:

1. Boulevard
 - a. SR 674
2. Main Street
 - a. 4th Street and 7th Street
3. Multimodal Avenue
 - a. North Street, Center Street, Hillsborough Street, West Lake Drive
4. Neighborhood Street
5. Greenway/Trail

Street Types	Main Street Core	Downtown Center	Downtown Residential	Government District	Light Industrial and Commercial	Village Residential (WVR-2)
Boulevard	✓	✓	✓	✓	✓	✓
Main Street	✓					
Multimodal Avenue	✓	✓	✓	✓	✓	✓
Neighborhood Street	✓	✓	✓		✓	✓
Greenway/Trail	✓	✓	✓	✓	✓	✓

Table 8-1

Section 3.23.09. – Streetscape Standards for the Main Street Core, Downtown Center, Downtown Residential, Government District, and Wimauma Light Industrial and Commercial

Definition of zones within cross sections.

1. Frontage Zone. The area adjacent to properties, such as building entrances, front yards, stoops, window shopping area, vending, café seating, and building-related utilities. This area may be part of the public right-of-way, or private, if a building setback is present.
2. Pedestrian Clearway Zone. The most important area of the street for safe, accessible, and efficient movement of pedestrians. The width depends on the street context. The minimum will be higher on streets with greater pedestrian activities. An adequate pedestrian clearway is most important in sidewalk design.

DRAFT 06.21.2021

3. Furnishing and Planting Zone. This zone in the boulevard provides space for a wide range of street elements such as trees, other plantings, litter and recycling bins, benches, streetlights, and bicycle racks. Street trees are encouraged at a spacing of 25 feet to 30 feet on center.
4. Edge Zone. The space behind the curb that acts as a buffer between moving/parked vehicles and the other sidewalk/boulevard functions. Should accommodate decorative street lighting. May accommodate signposts, parking machines, decorative pavers, and garbage set out.
5. Planted buffers are the preferred protection or separation for bicycle lanes within the roadway.
6. Utilities are encouraged to be installed underground.

Street Type Cross-Sections

DRAFT 06.21.2021

1. Boulevard

A. West of West Lake Drive

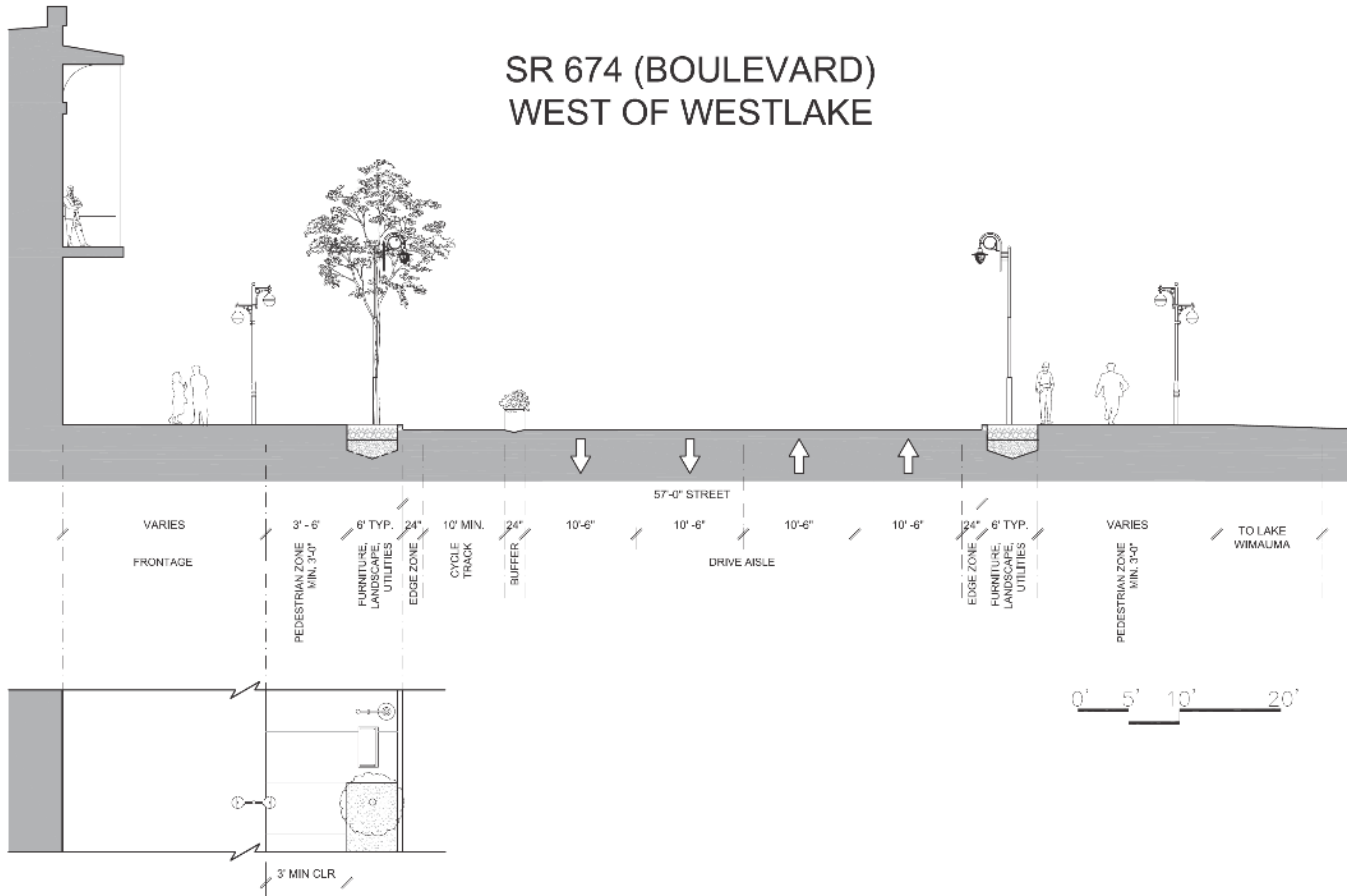

*Decorative street lighting should be installed in the Furnishing Zone, or within the area between the Pedestrian Zone to the Edge Zone

*Street trees are encouraged at a spacing of 25 feet to 30 feet on center.

*Planted buffers are the preferred protection or separation for bicycle lanes within the roadway.

*Utilities are encouraged to be installed underground.

DRAFT 06.21.2021

B. East of West Lake Drive

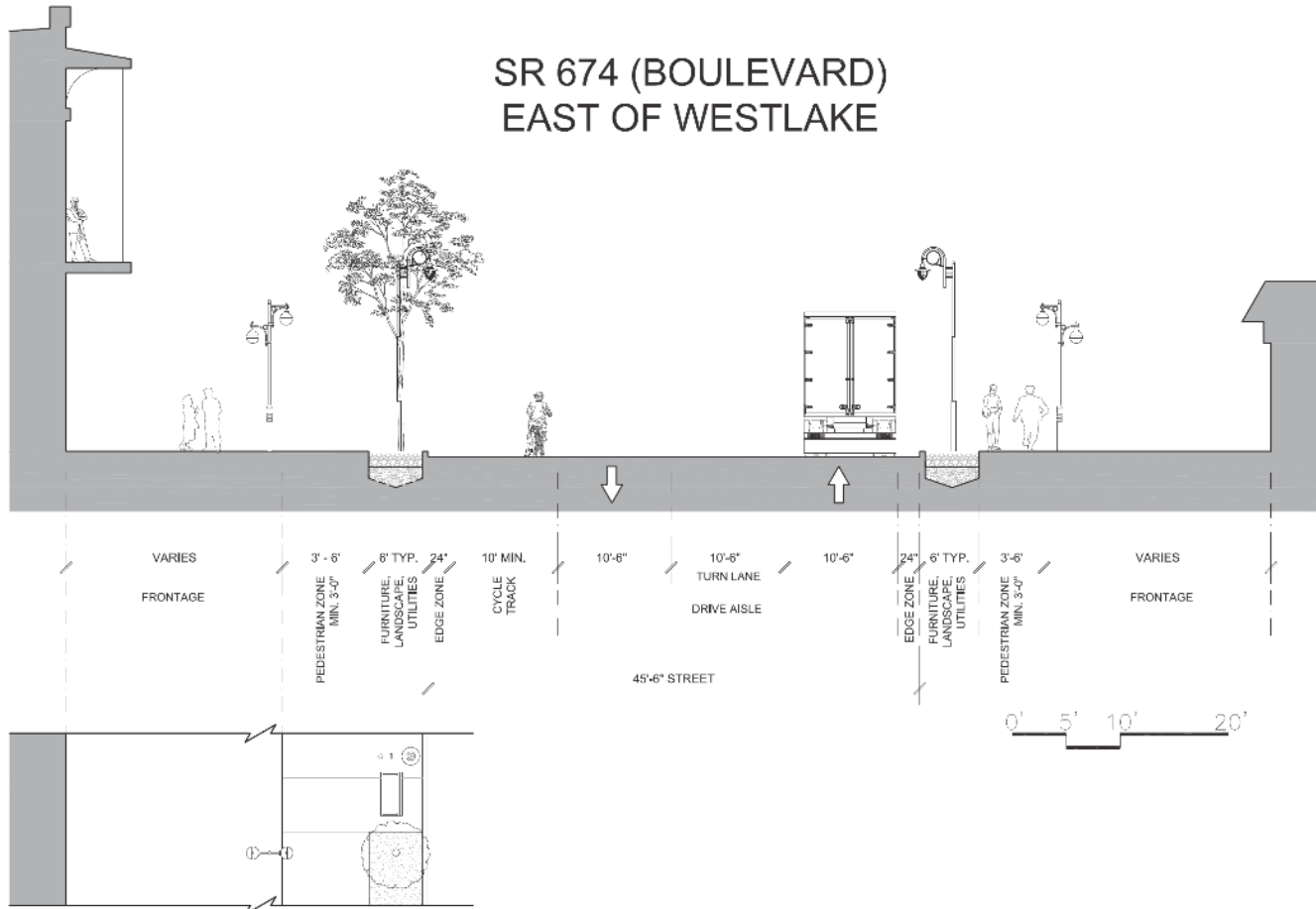

*Decorative street lighting should be installed in the Furnishing Zone, or within the area between the Pedestrian Zone to the Edge Zone

*Street trees are encouraged at a spacing of 25 feet to 30 feet on center.

*Planted buffers are the preferred protection or separation for bicycle lanes within the roadway.

*Utilities are encouraged to be installed underground.

2. Main Street

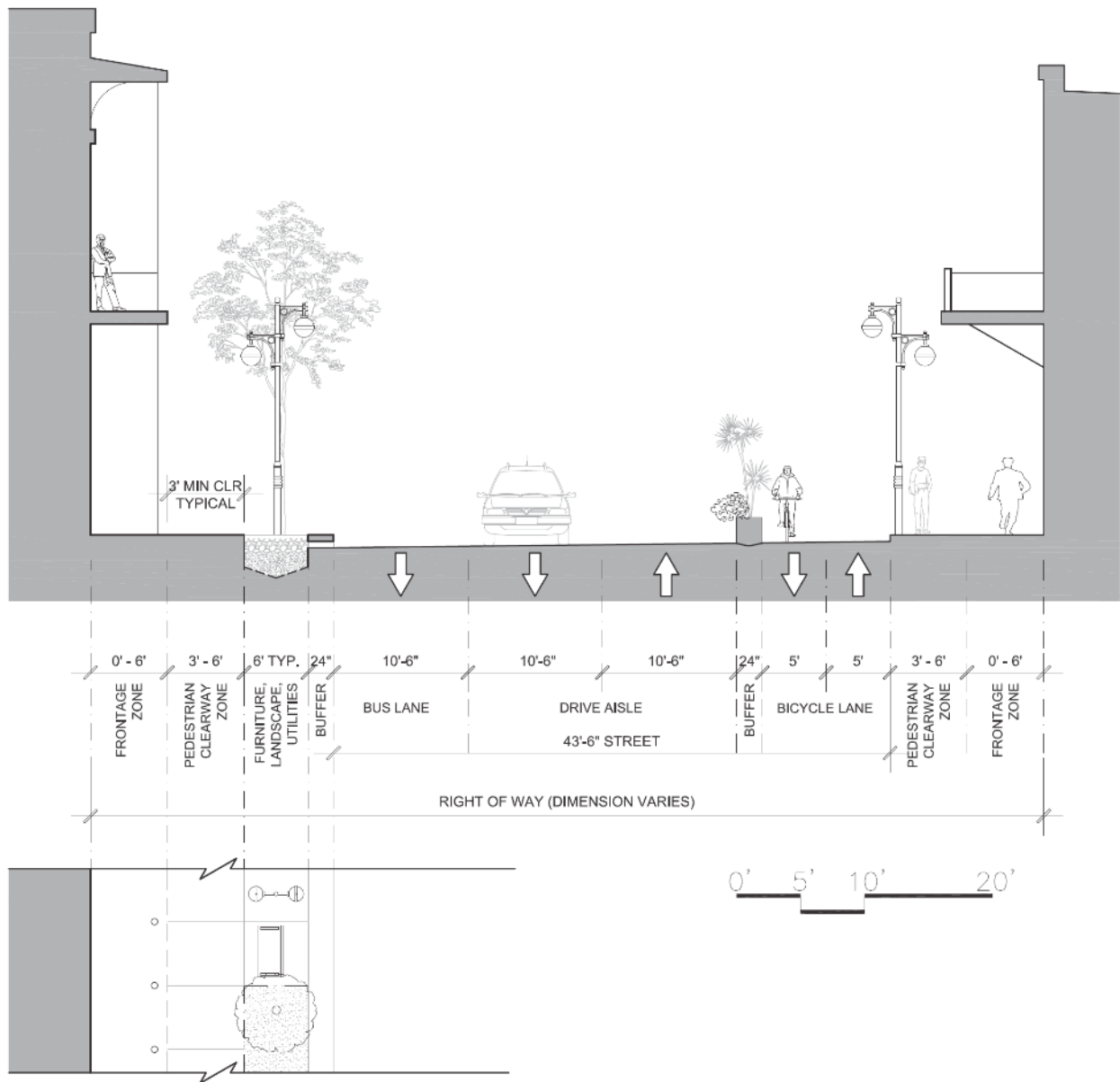

*Decorative street lighting should be installed in the Furnishing Zone, or within the area between the Pedestrian Zone to the Edge Zone

*Street trees are encouraged at a spacing of 25 feet to 30 feet on center.

*Planted buffers are the preferred protection or separation for bicycle lanes within the roadway.

*Utilities are encouraged to be installed underground.

3. Multimodal Avenue

NORTH STREET
(MULTIMODAL AVENUE)

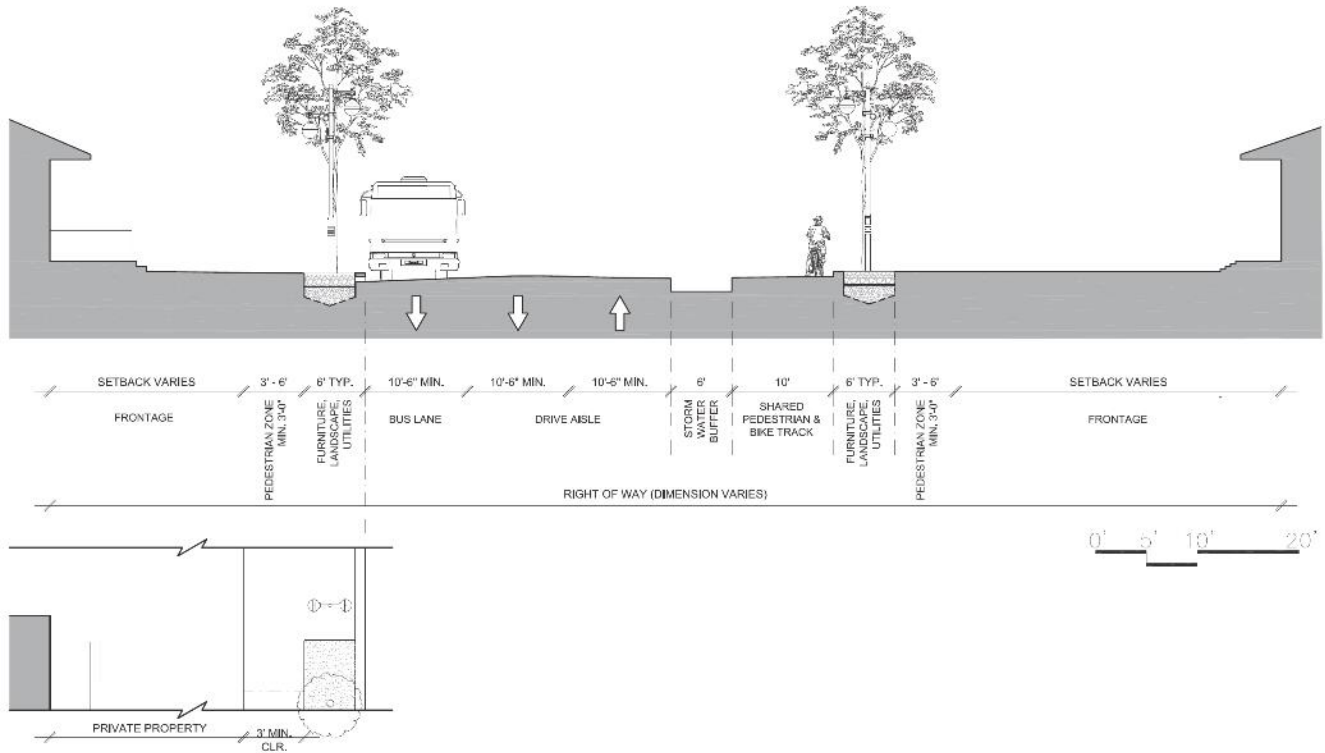

- *Decorative street lighting should be installed in the Furnishing Zone, or within the area between the Pedestrian Zone to the Edge Zone
- *Street trees are encouraged at a spacing of 25 feet to 30 feet on center.
- *Planted buffers are the preferred protection or separation for bicycle lanes within the roadway.
- *Utilities are encouraged to be installed underground.

4. Neighborhood Street

NEIGHBORHOOD

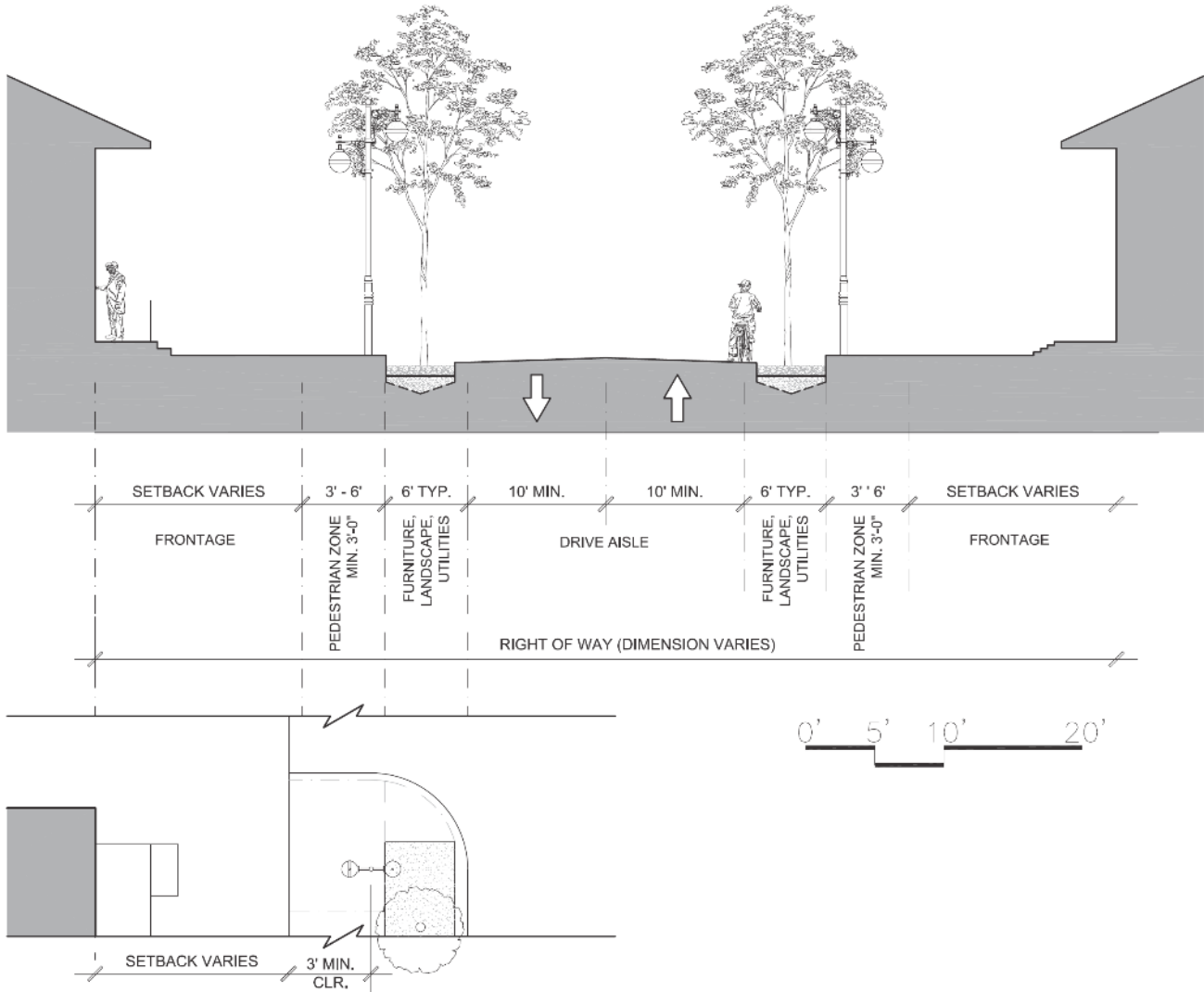

- *Decorative street lighting should be installed in the Furnishing Zone, or within the area between the Pedestrian Zone to the Edge Zone
- *Street trees are encouraged at a spacing of 25 feet to 30 feet on center.
- *Utilities are encouraged to be installed underground.

5. Greenways

WIMAUMA RECREATIONAL CORRIDOR
SHARED TRAIL

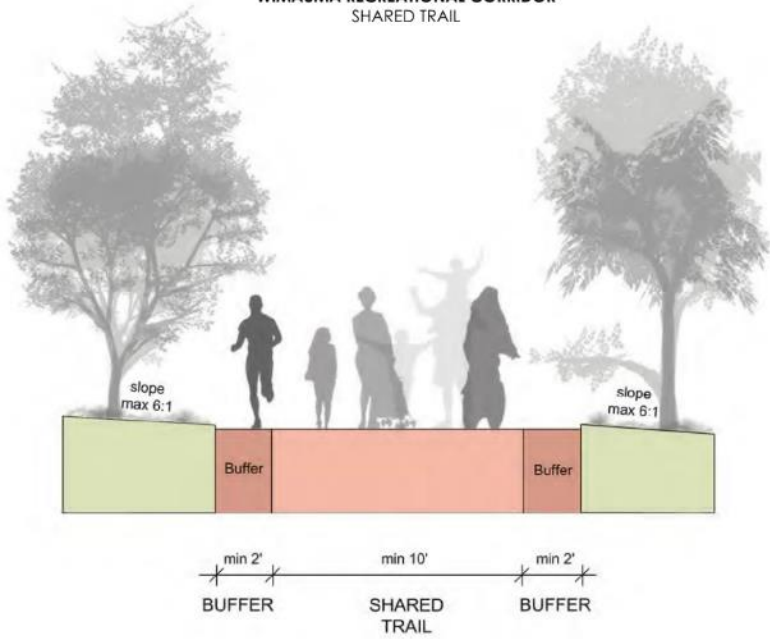

BIKE TRACK

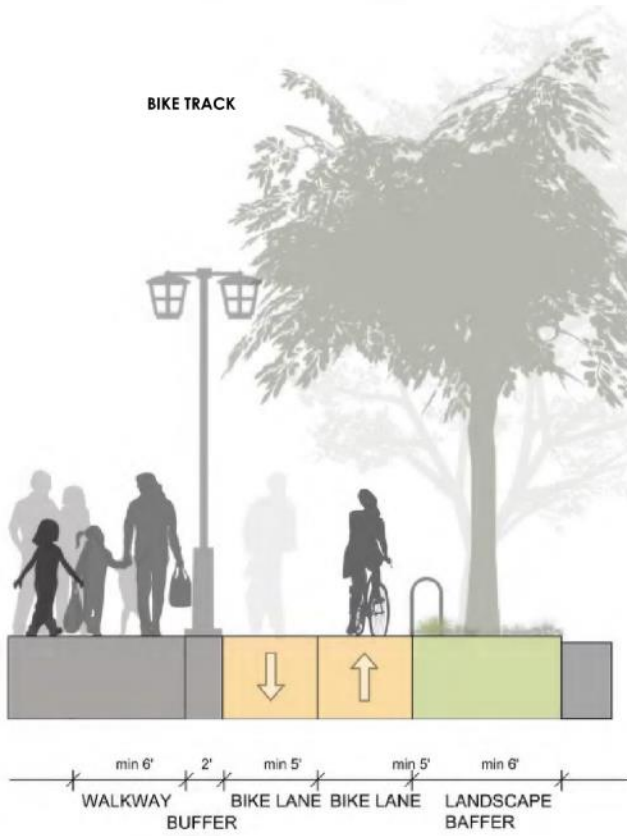

BUFFERED BIKE LANE

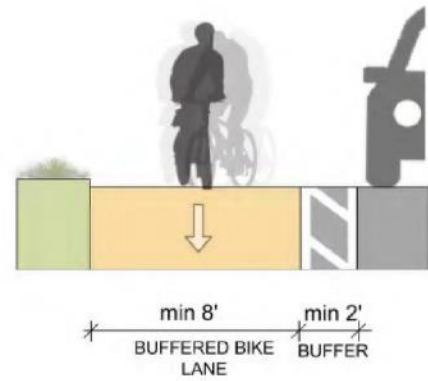

DRAFT 06.21.2021

Section 3.23.10. - Street Network Design

1. Development must accommodate the grid-like pattern in Wimauma Downtown as represented in the Plan.
2. Wimauma Downtown must provide an interconnected network of streets, alleys or lanes, and other public passageways.
 - A. Downtown streets must be designed to encourage pedestrian and bicycle travel by providing short routes to connect residential uses with nearby commercial services, schools, parks, and other neighborhood facilities within downtown or adjoining developments and neighborhoods. Sidewalks, rows of street lighting, and street trees must be provided on both sides of all downtown streets.
 - B. Downtown streets should be organized according to a hierarchy based on function, size, and design speed. Rights-of-way are expected to differ in dimension and must meet the appropriate county standards for safety.
 - C. Downtown streets should form an orthogonal grid and are required to intersect at ninety-degree angles.
 - D. Downtown must accommodate one or more public transit nodes for future service to points beyond the Village.
 - E. All streets must be publicly dedicated. Private streets and closed or gated streets are prohibited.
 - F. The use of raised intersections, lateral shifts, and traffic circles are encouraged as alternatives to more conventional traffic calming measures such as speed bumps.
 - G. Cul-de-sacs are not permitted except where physical conditions such as freeways provide no practical alternatives for connection for through traffic. Each cul-de-sac must be detailed as a close, with landscaping in the center.
 - H. Provide pedestrian networks that offer clear circulation paths from Off-Street Parking Areas to building entrances
 - I. Provide connections to the Wimauma Greenway Trail adjacent to Downtown.

Section 3.23.11. - Mobility, Parking, and Access for Main Street Core, Downtown Center, Downtown Residential, Government District, Wimauma Downtown West, and Wimauma Downtown East

Except as otherwise provided by this Section, parking requirements for all uses shall be in accordance with the Parking Standards of [Section 6.05.00](#). Landscaping requirements for off-street vehicular use areas shall be in accordance with the landscaping and buffering requirements of this Part.

1. Required Off-Street Parking

- A. Required parking provided through surface parking lots shall be on the development site or within 250 feet of the development site that the parking is required to serve. The off-site parking spaces shall be located within 250 feet walking distance of a public entrance to the structure or land area containing the use for which such spaces are required. A safe, direct, attractive, lighted, and convenient pedestrian route shall exist or be provided between the off-site parking and the use being served.
- B. Off-site required off-street parking shall not be separated from the use it serves by arterial or collector streets, or other similar physical barriers to convenient access between the parking and the use.

DRAFT 06.21.2021

C. In projects with off-street surface parking, parking lots are encouraged to be located at the rear of the building. Parking shall be located behind the line of the building façade fronting Main Street and all streets in the Wimauma Downtown Overlay.

D. The parking requirements in [Section 6.05.00](#) of this Code for non-residential uses may be reduced by 50 percent.

E. On-Street Parking Credit. On-street parking spaces shall be deducted from the required number of off-street parking spaces for the adjacent use. When an extended parcel line splits an on-street parking space, that space shall be deducted from the parking requirements of the parcel that fronts the majority of the on-street parking space not withstanding other sections of the code.

F. Bicycle Parking. Bicycle parking facilities are required to be provided within the project. Bicycle parking must meet the design standards of [Section 6.05.02](#) of this Code.

2. Parking Garages

A. Except for vehicle entrances, the ground floor shall be developed with enclosed commercial, office or civic floor space to a minimum building depth of 30 feet along the entire length of the structure on each adjacent street, unless separated from the street by another building, parking lot and/or landscaped open space with a minimum depth of 30 feet.

B. Direct pedestrian access in the form of pedestrian entrances and walkways from parking garages to each adjacent street shall be provided.

C. Parking Garages are encouraged in the Downtown Center, Government District, and Light Industrial and Commercial District.

3. Connectivity

A. Parking, service drives, and alleys shall be designed to allow for future connections to adjacent parcels and to allow all development along State Road 674 to be accessible from a street with an intersection at State Road 674, subject to FDOT approval.

B. Direct pedestrian access in the form of pedestrian entrances, sidewalks, crosswalks, and other walkways from public sidewalks to building entrances and between parcels shall be provided.

C. Adequate consideration for the access needs of disabled or handicapped residents and visitors through the provision of special parking spaces, accessible routes between Off-Street Parking Areas and buildings, passenger loading zones and access to other facilities in order to give disabled persons an increased level of mobility.

4. Utilities

Where possible, all utility lines for newly constructed structures shall be located underground.

A. Utility poles and other utility infrastructure shall not obstruct Main Street sidewalks and pedestrian areas within the public realm throughout Wimauma Downtown.

5. Storm Water

Storm water retention/detention ponds with slopes steeper than 4-to-1 shall be located to the rear of all principal buildings on the parcel and not within any buffer. Chain link fencing around storm water ponds shall be prohibited.

A. Low Impact Design for stormwater management and runoff are encouraged to enhance the rural character and small town feel of Wimauma.

DRAFT 06.21.2021

6. Joint Use Facilities and Shared Parking

Nothing in this Section shall be construed to prevent the joint use of off-street parking or off-street loading space for two or more structures or uses, if the total of such spaces, when used together, will not be less than the sum of the requirements of the various individual uses computed separately in accordance with the requirements of this Code.

A. An agreement for such joint use, in the form of a reciprocal easement acceptable to the office of the County Attorney shall be filed with the Administrator and recorded with the Clerk of the Circuit Court for Hillsborough County, Florida.

B. No part of an off-street parking area or off-street loading area required for any structure or use for the purpose of complying with the provisions of this Code, shall be included as a part of an off-street parking area or off-street loading area similarly required for another building or use, unless the Administrator determines that the periods of peak usage of such buildings or uses will not be simultaneous with each other.

C. All development orders or permits covering such approval shall include the requirements that the order or permit is valid only so long as the conditions described in the application for order or the permit exist.

Section 3.23.12. - Screening for Main Street Core, Downtown Center, Downtown Residential, Government District, Wimauma Downtown East, and Wimauma Downtown West

A. Trash, recycling receptacles, loading docks, service areas, and other similar areas must be located in parking areas or in a location that is not visible from the street frontages, and must be screened to minimize sound and visibility from residences and to preclude visibility from adjacent streets. Service areas shall be screened by a masonry wall and landscape buffer. The wall shall be a minimum of six feet in height using architectural design, materials and colors that are consistent with those of the primary structure. The landscape buffer shall be a minimum of five feet in width and contain evergreen plants a minimum of three feet in height at the time of planting and spaced not more than four feet apart.

B. Mechanical equipment shall be placed behind the line of the primary building façade and shall be screened from view of any street by fencing, vegetations, or by being incorporated into a building.

C. All rooftop mechanical equipment shall be integrated into the overall mass of a building by screening it behind parapets or by recessing it into roof structure.

D. Fences and walls shall be constructed of masonry, vinyl or cast iron/metal. The location of all fences and walls shall be in accordance with Part [6.07.00](#) of this Code throughout the overlay.

E. Landscaping, irrigation, and buffering, including off-street vehicular use areas, street trees, and buffering and screening between incompatible land uses, shall be in accordance with Part [6.06.00](#) of this Code.

F. Perimeter buffer along ROW. On any parcel of land providing an off-street vehicular use area, where such area is not entirely screened from an abutting right-of-way by an intervening building or other structure, a landscaped buffer a minimum of eight feet in width shall be provided between the off-street vehicular use area and the right-of-way, unless the buffer or screening requirements of Part [6.06.06](#) are more stringent, in which case the more stringent requirements shall apply.

DRAFT 06.21.2021

Section 3.23.13. - Sign Standards Signs within the WD Overlay as illustrated in Figure 1, herein, shall conform to the limitations and provisions of Article VII of this Code and must be constructed of materials similar to those of the buildings served. Additionally, the following limitations and provisions shall apply.

1. Structural Alteration and/or Replacement.

Notwithstanding the applicability provisions of this Part, structural alteration and/or replacement of existing signs that do not conform to the requirements of this Part on parcels within the Overlay District as shown in Figure 1. herein, as well as on any other parcel that is aggregated for development with a parcel shown in Figure 1, shall not be permitted, regardless of whether any building activity is occurring on the parcel at the time, except that such signs may be removed and replaced with signs conforming with the requirements of this Part.

2. Nonconforming Signs.

Notwithstanding the applicability provisions of this Part and regardless of whether any building activity is occurring on the parcel at the time, nonconforming signs may be removed and replaced with signs conforming with the requirements of this Part, and those illegal nonconforming signs as identified in Section 7.02.03.A which should have been removed or modified under prior law shall only be removed and replaced with signs conforming with the requirements of this Part. Variance requests to allow the continued use of existing nonconforming monument signs shall be considered pursuant to the sign standards of this Part.

3. Replacement of Advertising Copy or Panels.

Replacement of advertising copy or panels on such signs that do not involve structural alterations shall be allowed if otherwise permitted by this Code.

4. Pole Signs, Animated Signs and Changeable Copy signs and Revolving Signs.

Use of Pole Signs, Ground Signs extended from the ground, Animated Signs, Changeable Copy signs and Revolving Signs shall be prohibited; exceptions may be made for emergency public services/uses. Variances to allow the continued use of existing on-site pole signs, ground signs extended from the ground, or revolving signs, or the installation of new pole signs or revolving signs, shall be prohibited.

5. Sign Lighting.

Sign lighting fixtures shall be hidden from view by landscaping. All other sign lighting shall conform to the limitations and provisions of Part [6.10.00](#) of this Code.

Section 3.23.14. - Transfer of Development Rights (TDR) Receiving Zone

The development rights attached to a parcel of land can sometimes be transferred to other parcels. The TDR Element encourages the transfer of density for several purposes: to move potential development to certain locations inside the USA; to encourage continued use of land for rural and open space purposes by transferring potential density off the land which maintains value of the sending zone; and to allow the accumulation of sufficient development rights to support downtown development.

1. Allow for the transfer of up to 2 dwelling units per gross acre (DU/GA) densities between 2 separately owned or commonly held properties, whether or not they are contiguous to each other.

DRAFT 06.21.2021

The designated sending area shall be inside the limits of the Wimauma Village Residential-2 category and other rural areas outside of USA.

A. Downtown Receiving Zone: The designated receiving areas shall be inside the Wimauma Village Residential-2 category, inside the Urban Service Area portion of the Wimauma Village Plan, or in the Wimauma Downtown Receiving Zone.

2. To support housing growth in the Wimauma Downtown and preserve rural areas within the WVR-2, the exchange ratio for transfer of dwelling units into the priority receiving zone of the Wimauma Downtown Main Street Core will be 2 DU/GA to 4 DU/GA, a ratio of 1:2 (except in WVR-2 to WVR-2 transfers, the ratio is 1:1). No property shall be left with less development rights than there are existing dwellings on said properties, or less than 1 dwelling unit development for any parcel which would otherwise be eligible for a dwelling unit. TDR tracking shall be via file-permanent deed restriction to be in the form of a conservation easement consistent with Section 704.06, Florida Statutes, to be granted by the owner of the sending parcel and accepted by the Board of County Commissioners and recorded in the official public records prior to preliminary plat approval for the receiving area.

3. To support the Main Street Core and economic development, stacking of TDR and Affordable Housing Density Bonuses will be allowed and encouraged in the Downtown Receiving Zone (Figure 1).

Section 3.23.15. – Affordable Housing Density Bonus

To encourage a broad range of family sizes and incomes Affordable Housing is encouraged and may be used in conjunction with TDR credits resulting in a stacking of density bonuses.

1. Affordable housing must be made available on approximately the same schedule as the balance of housing in each phase of a project; affordable housing may not be deferred until the final phases.

A. A specific schedule for the types, location, and phasing of construction of affordable housing must be proposed with each application.

2. Affordable housing must be sold or rented only to qualified households as defined by Hillsborough County.

A. 60% of the required affordable housing must be affordable to families earning below 50% of the County's Area Median Income (AMI). 40% of the required affordable housing must be affordable to families earning 50% to 80% of the County's AMI.

3. The bedroom mix of affordable housing units must be proportional to the bedroom mix of the market rate units.

4. "Floating" units are preferred in lieu of designating specific units within multi-family development, and Town House/Rowhouse developments.