

DRAFT 06.21.2021

PART 3.24.00 – Wimauma Village Residential Neighborhood

Section 3.24.01. – Purpose

The purpose of this Part is to establish development standards for residential developments within the Wimauma Village Residential Neighborhood (as shown in Figure 2-1) seeking to develop at gross densities greater than 1 unit per 5 acres, referred to in these regulations as a Wimauma Village Neighborhood. The design standards implement the vision, principles, and strategies of the Wimauma Community Plan, as found in the *Future of Hillsborough* Comprehensive Plan. The intent of these regulations is to improve and encourage connectivity with Wimauma's Downtown areas and establish a residential district with a sustainable growth pattern.

Compliance with these regulations shall be reviewed through a Planned Development – Wimauma Village Neighborhood (PD-WVN) application. Each rezoning shall clearly demonstrate compliance with the following regulations.

Section 3.24.02. – Applicability

Except as provided herein, these standards shall apply to all new residential development exceeding a gross residential density more than 1 unit per 5 acres and to all development aggregated with development within the Wimauma Village Residential Neighborhood area as of October 1, 2021.

1. These provisions shall not apply to public schools and previously approved planned developments, previously approved subdivisions, projects with unexpired building permits, unexpired preliminary site development approval, or unexpired construction plan approval as of October 1, 2021.
2. In addition to the standards provided herein, development of a Wimauma Village Neighborhood shall be required to meet all other applicable sections of the Land Development Code. Where any provision of these regulations conflict with any other standards or regulations of the Land Development Code, these regulations shall prevail.
3. Minor and major modifications to pre-existing Planned Developments within the applicable area shall be evaluated for consistency with these regulations and shall comply to the greatest extent possible. In applications where only a portion of the pre-existing Planned Development is proposed for minor or major modification, these regulations shall only apply to the portion of the project subject to the modification.

Figure 2-1

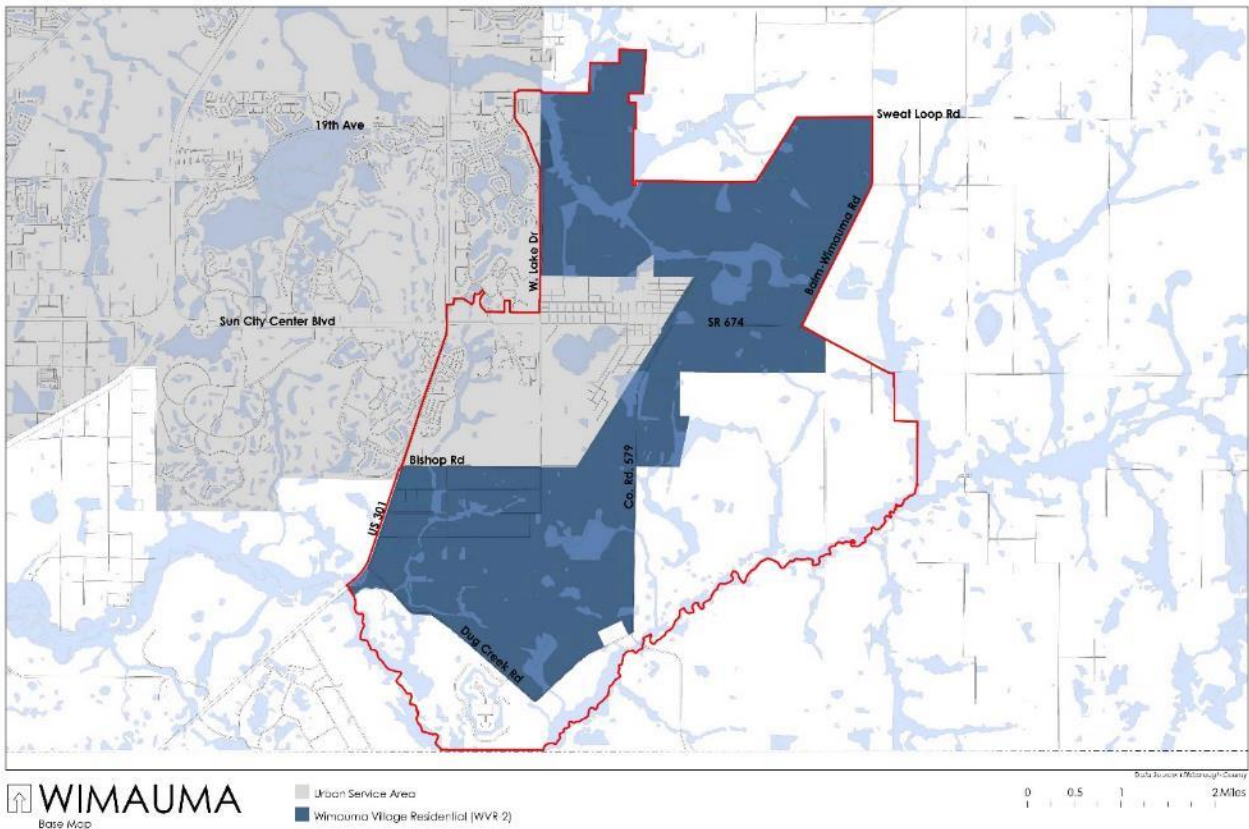

Section 3.24.03. - Permitted Uses

Uses shall be permitted as approved by Planned Development rezoning.

Section 3.24.04. - General Development Standards

1. Projects shall meet a clustering ratio of at least 4 units per net acreage. Net acreage shall consist of all land not designated as Open Space or Civic Building Lot acreage.
2. Projects shall designate at least 40% of the gross site acreage for Open Space to ensure that the rural landscape is preserved. To achieve compliance with the minimum clustering ratio, the designation of additional Open Space may be required. 30% of the open space must be contiguous or adjoining, and 10% of the open space must be internally located to the PD site neighborhoods and does not have to be contiguous. The locations of the Open Space shall be reviewed at the time of rezoning and be dependent upon the internal layout of the project, existing environmental features of the site, and adjacent uses. The plan must demonstrate connection to internal and neighboring open space or conservation areas, if applicable. Areas of the site that shall be considered Open Space shall be those permitted in the Rural Service Area per the *Future of Hillsborough* Comprehensive Plan. In addition, the following areas may be considered:
 - Recreation (to include, but not be limited to, walking paths, equestrian trails, off-road bicycle paths, tot lots, plazas, and greens).

DRAFT 06.21.2021

- Stormwater ponds that are designed in a manner to allow for open space and/or passive recreation available to all neighborhood residents.
- Community gardens
- Community gathering places with or without active recreational components
- Neighborhood Greens that do not include Civic Use Buildings
- Agricultural uses and facilities, agriculture-based targeted industry
- Restored or preserved native habitat and environmentally significant or sensitive land including wetlands and forestry

The following shall not count towards the Open Space minimum acreage requirement:

- Residential yards
 - Private golf courses
 - Amenity Areas (pools, clubhouses)
 - Stormwater ponds that do not provide public access
 - Civic Building Lots
3. Notwithstanding Land Development Code Section 6.11.02.A, accessory dwellings on any lot size are permitted. All other requirements of Land Development Code Section 6.11.02 are to be met. Accessory dwellings are not permitted on Apartment House or Courtyard House Lot Types.
 4. Neighborhood Centers: For developments of 100 acres or more neighborhoods shall be designed so that at least 50 percent of the housing units are within a five-minute walking distance (i.e. no more than a quarter mile radius measured via straight line measurement) from the perimeter of a Neighborhood Center. Multiple Neighborhood Centers may be provided within a single development.

Neighborhood Centers shall be located inside of the Neighborhood or on the periphery of the Neighborhood near the right of way at the entrance of the Neighborhood. Neighborhood Centers shall include one or more of the following which can be defined as non-residential uses: parks (public and/or private, to be maintained by HOA if private) government/public service uses, public or private schools, community gardens, farmers markets, churches, residential support uses (i.e. daycares or assisted living facilities), general indoor recreational uses, live/work units.

- i. The acreage of the Neighborhood Center shall be at least 1.5% of the gross acreage of the project. Non-enclosed uses, such as community gardens, parks and farmer's markets which are part of a larger Neighborhood Center, shall contribute a maximum of 50% of the requirement (not including required parking areas that serve the non-enclosed uses).
5. Projects shall also provide a Community Benefit as provided below:

At least one benefit shall be offered for developments less than 25 acres.

At least two benefits shall be offered for developments less than 50 acres but equal to or greater than 25.

At least three benefits shall be offered for developments less than 100 acres but equal to or greater than 50.

DRAFT 06.21.2021

At least four benefits shall be offered for developments less than 160 acres but equal to or greater than 100.

At least five benefits shall be offered for developments less than 320 acres but equal to or greater than 160.

At least six benefits shall be offered for developments greater than 320 acres.

Should a pre-existing approved residential development located within the Wimauma Village Residential Neighborhood Area that has received Construction Plan approval as of October 1, 2021 be enlarged, the acreage of the area being added shall determine the number of community benefits to be provided. Should a pre-existing approved residential development located within the Wimauma Village Residential Neighborhood Area that has not received Construction Plan approval as of October 1, 2021 be enlarged, the acreage of the entire area shall determine the number of community benefits to be provided.

Section 3.24.05. - Permitted Lot and Building Form Types in the Wimauma Village Residential Neighborhood:

1. Each Wimauma Village neighborhood must contain a minimum of four (4) different Lot and Building Form types, if no Civic Building Lot is provided. The proposal of two Standard House Lot and Building Form types at two different lot sizes, lot widths and/or development standards shall be permitted to count for a maximum of two of the required four different Lot and Building Form types. For all other Lot and Building Form types, multiple lot sizes, widths, or development standards proposals of the same Lot and Building Form type shall only count as one of the four required Lot and Building Form types.
2. A Wimauma Village neighborhood must contain a minimum of four (4) different Lot and Building Form Types. If there is a Civic Building Lot provided within the Wimauma Village neighborhood, this may count as one (1) of the Lot and Building Form types. For all other Lot and Building Form types, multiple lot sizes, widths, or development standards proposals of the same Lot and Building Form type shall only count as one of the four required Lot and Building Form types.
3. No less than 10 percent and no more than 60 percent should be provided of one Lot and Building Form Type. Live/Work lots are encouraged – These lots may be established below the 10 percent threshold but shall not satisfy the required Lot and Building Type Forms. These lots shall be placed in or adjacent to Neighborhood Centers.
4. The land area for the Civic Building Lot(s) shall be located with direct access to neighborhood street networks, and be oriented to the Wimauma Recreational Trail where possible. The land area shall comply with the required block size maximums unless the proposed use can be demonstrated at the time of rezoning to require deviation from that requirement. The location of the Civic Building Lot within the overall project shall be evaluated at the time of rezoning and the location may vary from project to project based upon the subject site's environmental features, site layout and adjacent uses. The location of buildings on the Civic Building Lot shall face an improved street

DRAFT 06.21.2021

right-of-way and shall not be separated from the right-of-way by another building, stormwater facilities or parking areas or drive aisles. On parcels with multiple street frontages, buildings shall front the street with the higher functional classification. Civic Building Lot uses shall include libraries, County office buildings, daycares, religious institutions, and neighborhood places of assembly, that are not neighborhood amenity uses such as clubhouses. Enclosed, open, and quasi-enclosed Farmers Markets may also be considered a Civic Building Lot use and the farmer's market activity area (not to include associated parking) shall be calculated as FAR to meet the required building size and building location within the Civic Building Lot. Parking shall be provided to the rear or side of the building(s)/activity areas. Alternatively, the Civic Building Lot area may be developed fully as a Neighborhood Green, which shall be bound on all sides by streets, and improved landscaping, walkways, benches, fountains, gazebos and/or similar amenities to encourage and accommodate use by residents.

* BUILDING PLACEMENT REQUIREMENTS FOR CIVIC BUILDINGS VARY BY SITE. IN GENERAL, CIVIC BUILDINGS SHOULD BE SITED IN LOCATIONS OF PARTICULAR GEOMETRIC IMPORTANCE, SUCH AS ANCHORING A MAJOR PUBLIC SPACE, OR TERMINATING A STREET VISTA.

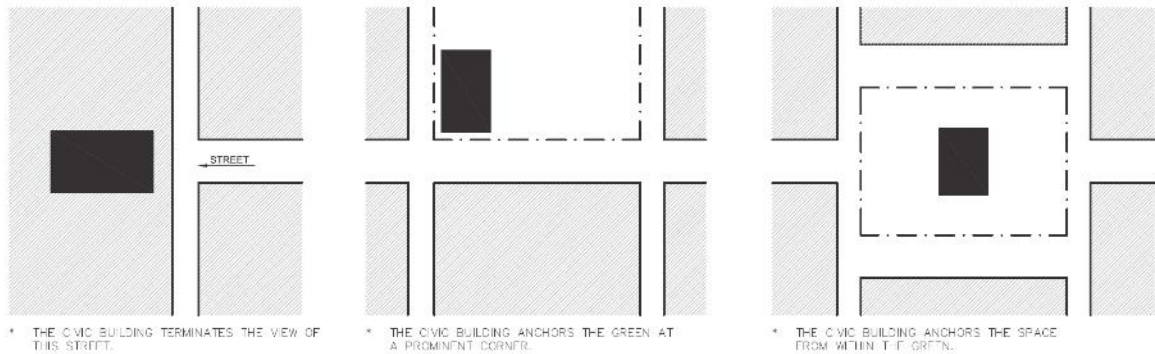

Illustrative Graphic Only

5. Differing lot and building form types should be placed back-to-back on a single block to provide harmonious transitions between lot types. Lot types should be selected to provide buildings of like scale and massing on opposite sides of streets.
6. Permitted lot and building form types in a Wimauma Village Neighborhood include the following:

Apartment House Lot
Courtyard Apartment Lot
Rowhouse or Town House Lot
Cottage House Lot
Sideyard House Lot
Standard House Lot
Civic Building Lot
Live/Work Lot

Section 3.24.06. - Development Standards for Permitted Lot and Building Form Types:

1. Front loaded garages must be setback 10 feet from the front façade of the main structure. Alley access garages are strongly encouraged. Building frontage to include attached front-loading garage or attached rear loading garage.

DRAFT 06.21.2021

2. Accessory Structures shall follow the primary building setback in Table 6-1 and not exceed two stories.
3. Accessory Dwellings may accommodate up to one dwelling unit.
4. Detached garages shall follow accessory structure setback requirements in Table 6-1 except for the Standard Building Lot where garages may be setback 5 feet from the property line.
5. In yards with required build-to lines for 0' side yard, the entire length of each building façade containing enclosed floor space shall be placed on the build-to line or, on parcels with curved or irregular build-to lines, the chord of the build-to line. Doorways and minor architectural features, such as transoms, sidelights and porticos, recessed into the façade shall be permitted. A maximum of one foot of relief from the build line shall be permitted for architectural features such as cornices and expression lines.
6. Conceptual illustrations below demonstrate lot size and dimensional requirements of Table 6-1.

Table 6-1 (Under review lot size)

LOT TYPE	LOT SIZE (min/max SF)	LOT WIDTH (min/max)	BUILDING FRONTAGE (min/max)	LOT COVERAGE BY BLDG (max)	YARD (min and max)			HEIGHT (min/max in stories; max in feet)
					FRONT(*1)	REAR	SIDE	
					Apartment House Lot	4,800/18,000	48/120	
Courtyard Apartment Lot	4,800/18,000	60/no max	50/80%	70%	5/10	10	0	1/2.5; 35'
Rowhouse Lot	1,800/3,840	16/32	90/100%	80%	0/10	15	0 (*3)	2/3; 35'
Cottage House Lot	2,400/4,800	24/40	70/90%	60%	5/25	10	2	1/2; 35'
Sideyard House Lot	3,000/6,000	30/60	60/90%	50%	5/10	10	0/10 (*2)	1/3; 35'
Standard House Lot	5,000/8,400	50/70	50/80%	50%	20/30	10	5	1/3; 35'
Civic Building Lot	5,000/no max	50/no max	n/a	80%	n/a	15	0	1/4; 50'

Table 6-1 Notes:

- (1) Corner lots must meet front yard requirements on both streets.
- (2) Sideyard house requires zero-foot setback on only one side, 10-foot setback on the other side, and no back to back zero foot side.
- (3) Rowhouses shall contain at least 3 attached units-
- (4) Garages are encouraged to be located at the rear of the lot.

DRAFT 06.21.2021

1. Apartment House (AH)

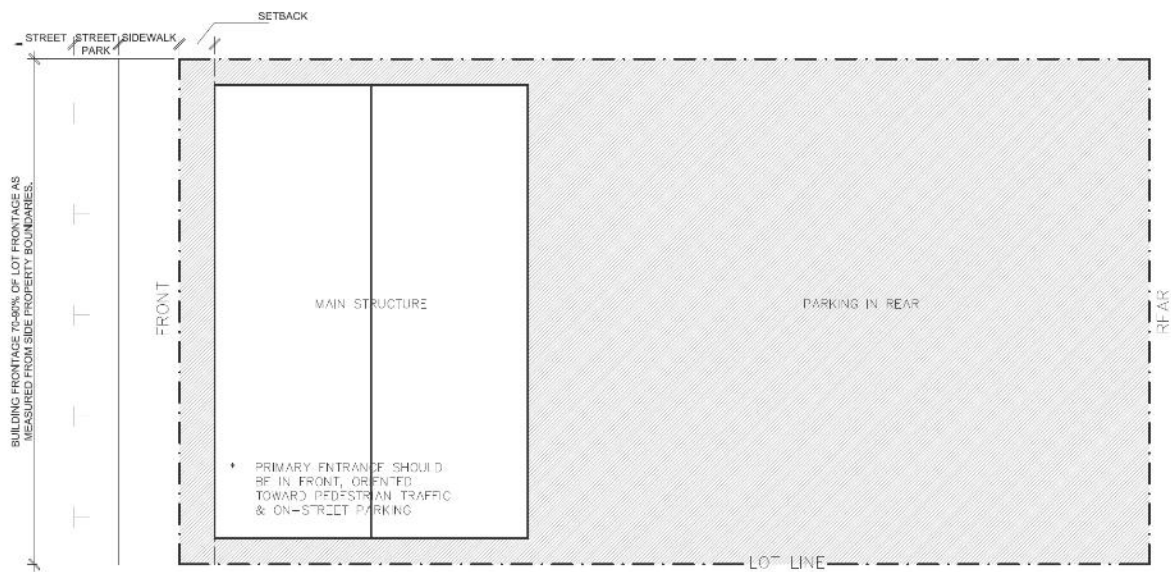
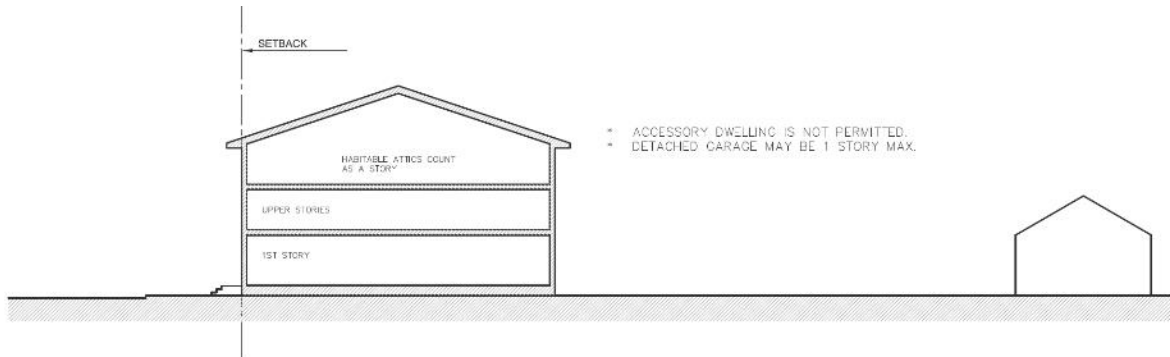

BUILDING PLACEMENT

Off-street parking for Apartment House lots shall be located behind or to the side of the main structure(s). No parking shall be located between the primary façade, or façade portion, closest to the street, and the street.

The building's primary orientation shall be toward the street rather than the parking areas. The primary building entrances shall be visible and directly accessible from a street.

Accessory Structures shall follow the primary building setback

DRAFT 06.21.2021

2. Courtyard Apartment (CA)

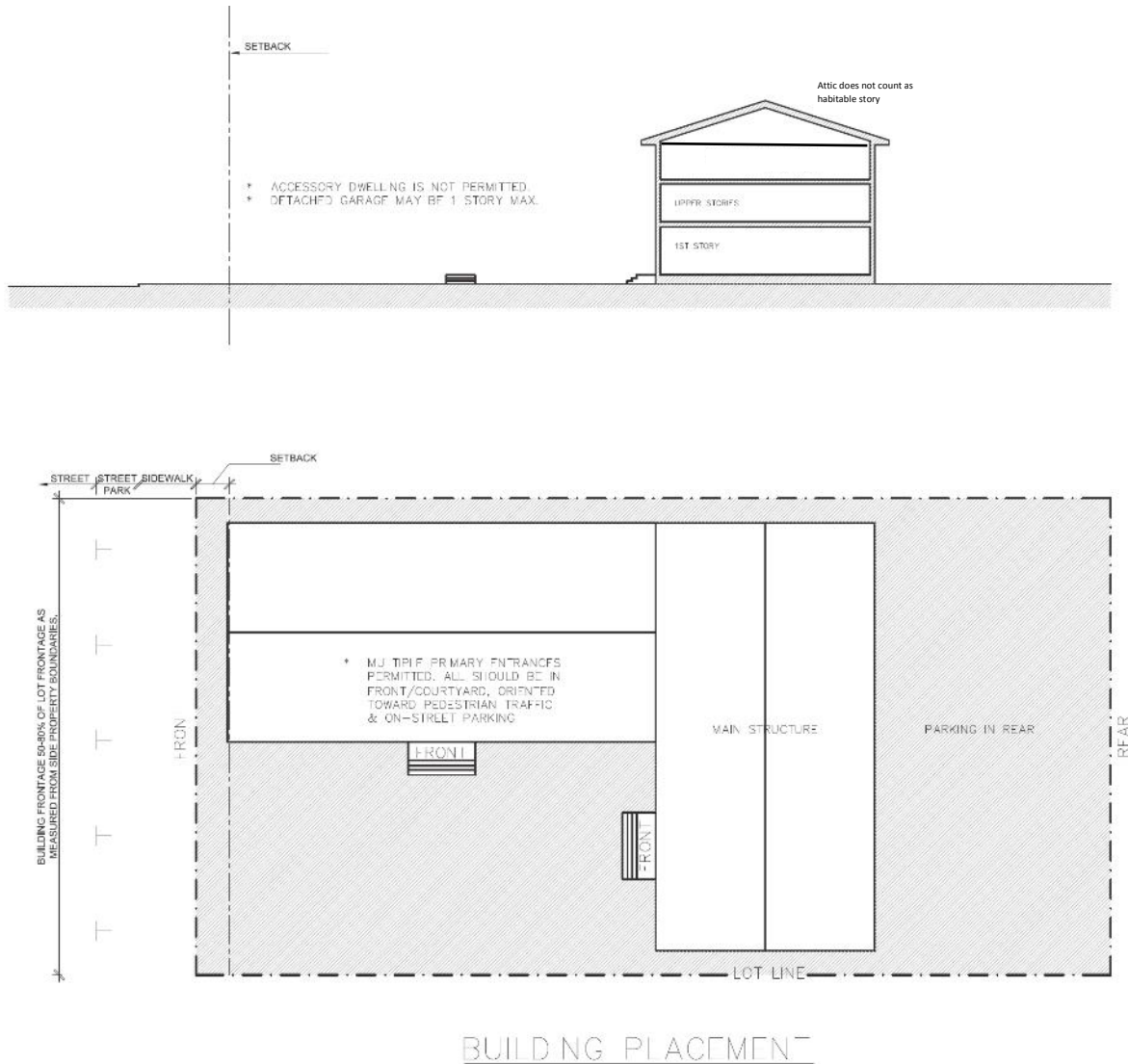

Off-street parking for Courtyard Apartment lots shall be located behind or to the side of the main structure(s). No parking shall be located between the primary façade, or façade portion, closest to the street, and the street.

The building shall provide two different building orientations. One of the building's primary orientations shall be toward the street rather than the parking areas. A primary entrance for each building orientation component shall be provided towards the street and/or courtyard.

Accessory Structures shall follow the primary building setback

DRAFT 06.21.2021

3. Rowhouse (RH) or Town House

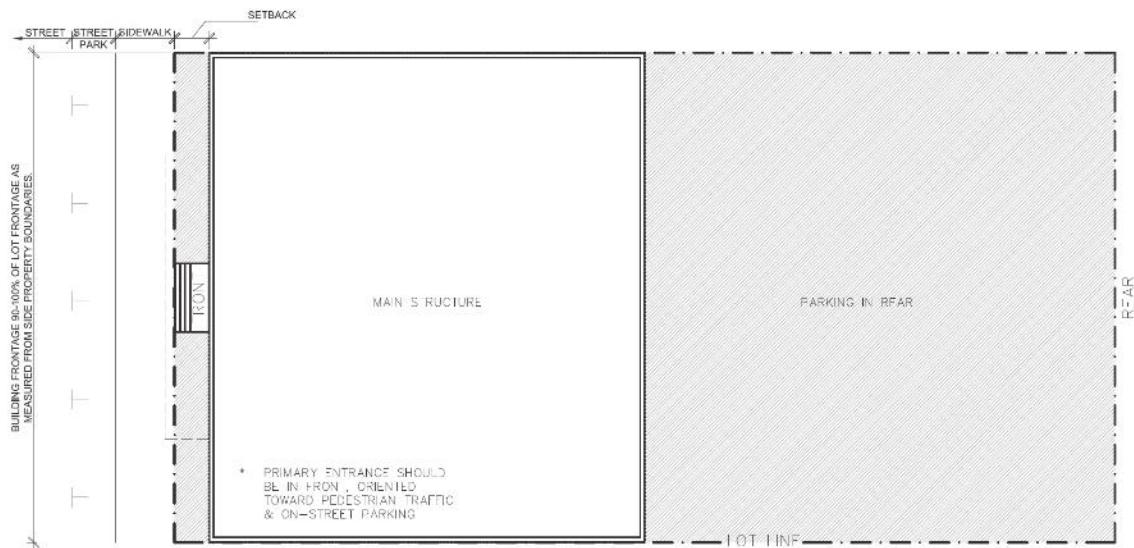
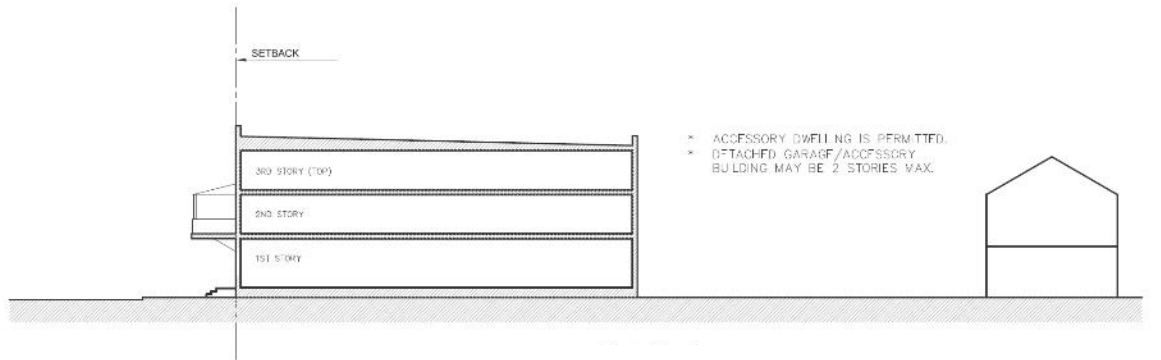

BUILDING PLACEMENT

Attached garages, accessed from the front of the property/street, shall be setback a minimum of 20 feet from the front property line. The remaining residential portion of the structure may be setback at the same distance or at a setback closer to the street. The residential portion shall not be located behind the garage. An offset of at least 10 feet shall be provided between the residential portion and garage portion of the structure when the garage is not flush with the residential facade.

Garages attached to the rear of the rowhouse buildings, accessed from the rear or side of the rowhouse building, are to be accessed via an alley located along the rear of the lot or from the front street via a driveway located to the side of the rowhouse building.

Detached garages, accessed from the rear or side of the rowhouse building, are to be accessed via an alley located along the rear of the lot or from the front street via a driveway

DRAFT 06.21.2021

located to the side of the rowhouse building.

Should the project provide a parking area, rather than individual garages, the parking area shall be located behind or to the side of the rowhouse building. No parking shall be located between the primary façade, or façade portion, closest to the street.

A building's primary orientation shall be toward the street rather than the parking areas. The primary building entrances shall be visible and directly accessible from a street.

Accessory Structures shall follow the primary building setback

DRAFT 06.21.2021

4. Cottage House (CH)

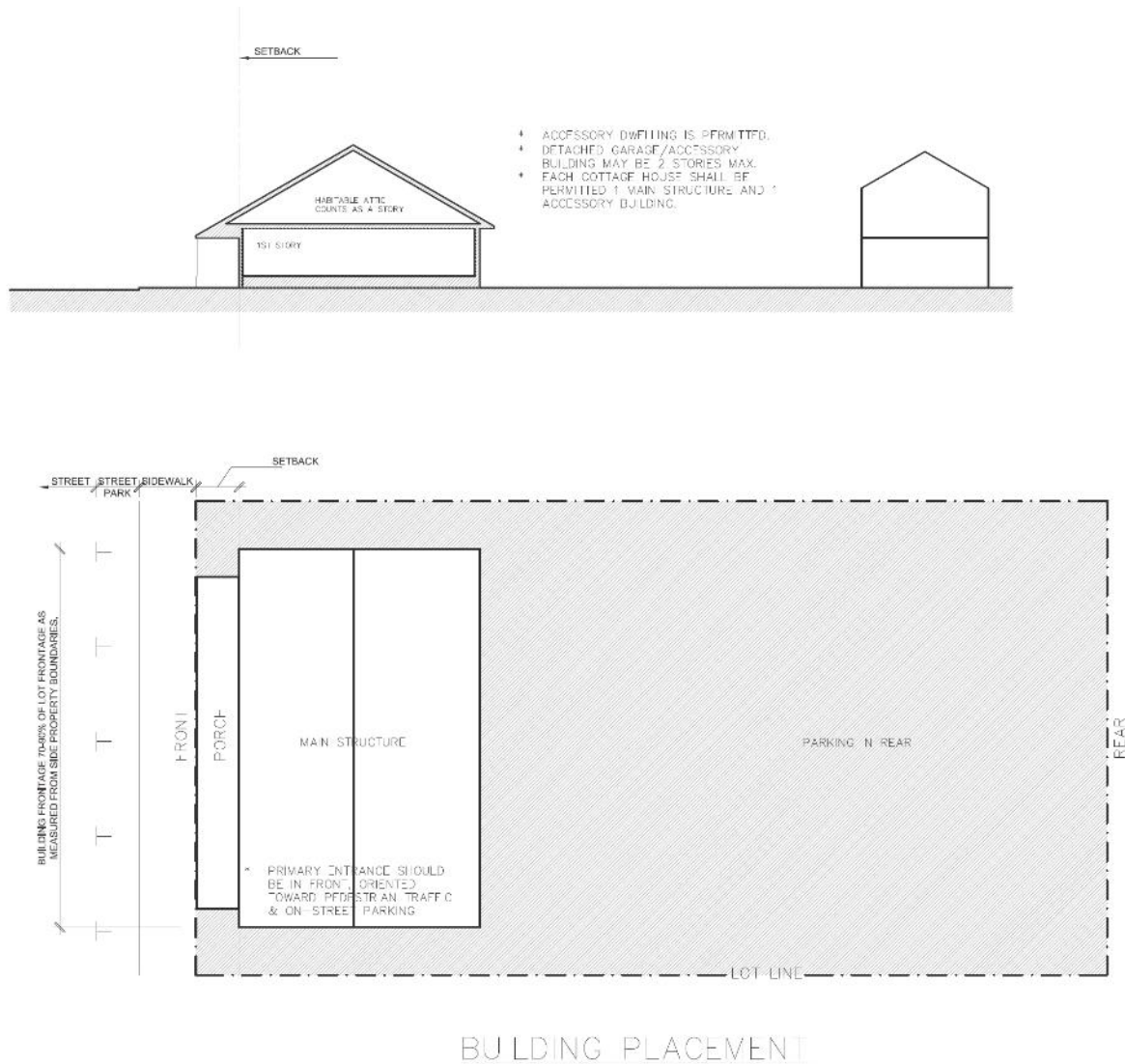

Each structure shall provide a porch along a minimum of 70% of the façade. The porch shall be used in the building frontage percentage calculation.

On-site parking shall be accommodated with a detached garage, or attached rear-loading garage, to be accessed via an alley located along the rear of the lot or from the street via a driveway located to the side of the home.

Accessory Structures shall follow the primary building setback

DRAFT 06.21.2021

5. Sideyard House (SH)

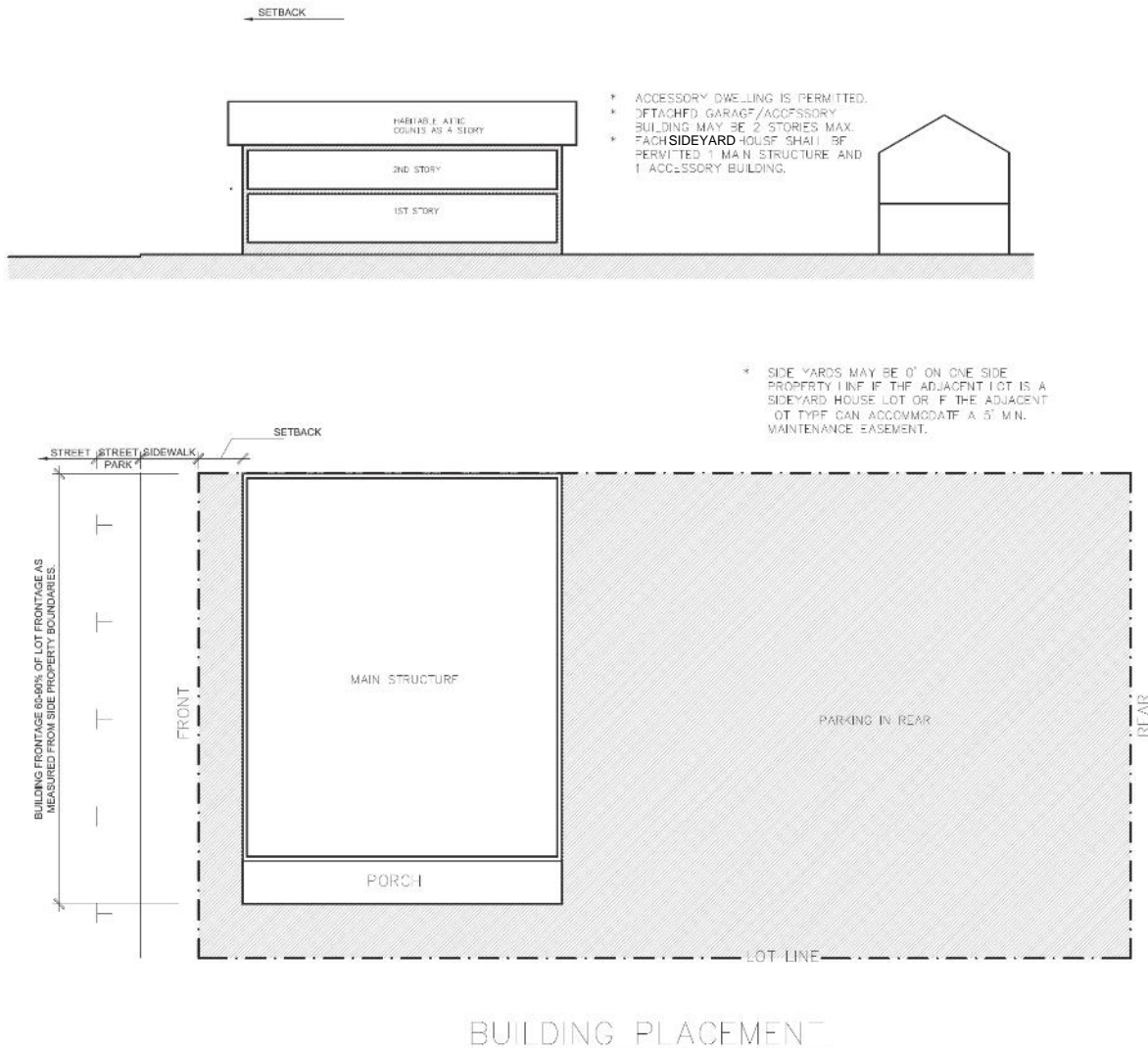

Each structure shall provide a porch along at least 75% of the side façade not placed at a 0-foot side yard setback.

On-site parking shall be accommodated with a detached garage, or attached rear-loading garage, to be accessed via an alley located along the rear of the lot or from the street via a driveway located to the side of the home.

Accessory Structures shall follow the primary building setback

6. Standard House (HO)

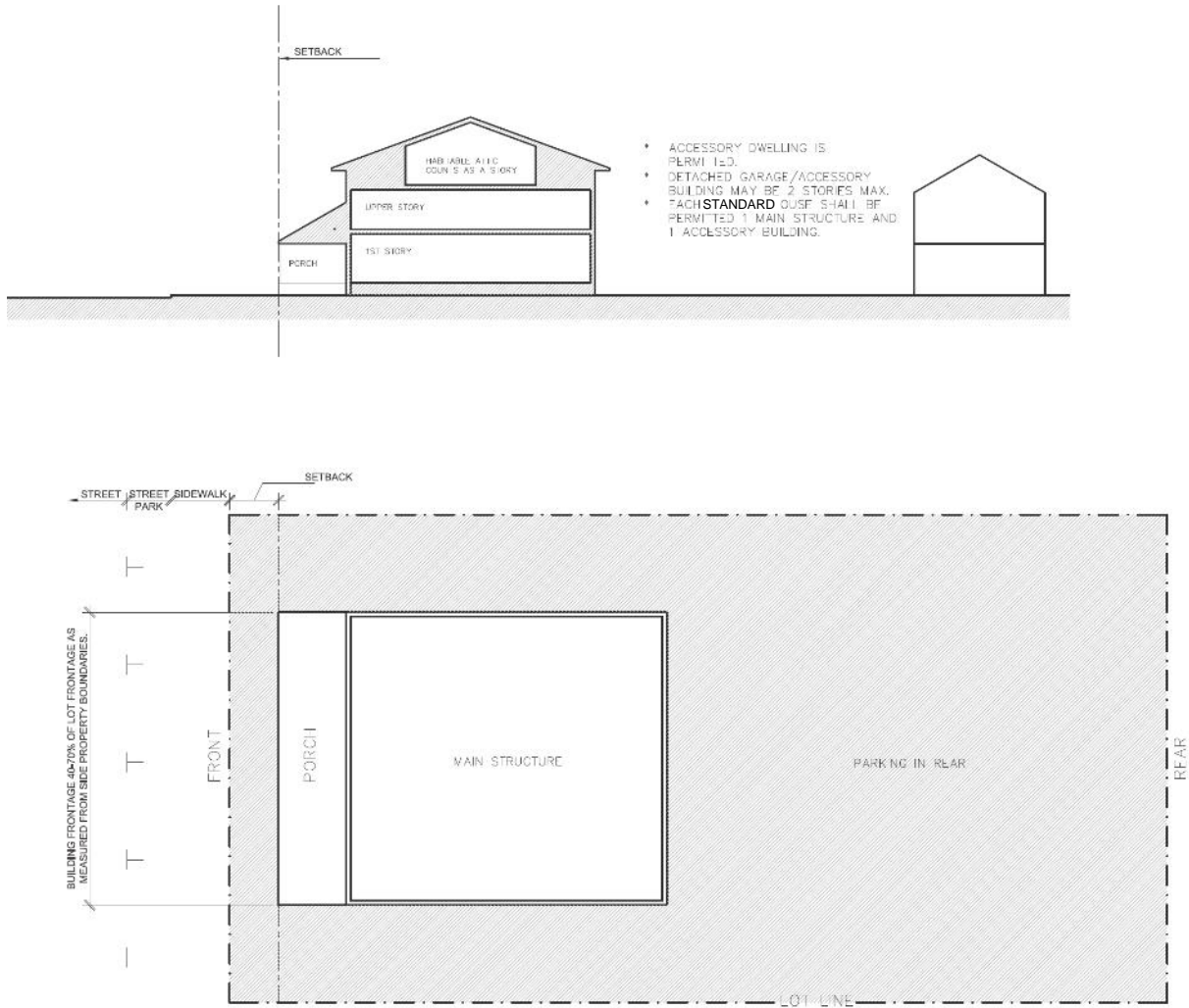

BUILDING PLACEMENT

On-site parking shall be accommodated with a detached garage, or attached rear-loading garage, to be accessed via an alley located along the rear of the lot or from the street via a driveway located to the side of the home.

Accessory Structures shall be setback 5 feet from the property line.

7. Civic Building (CB)

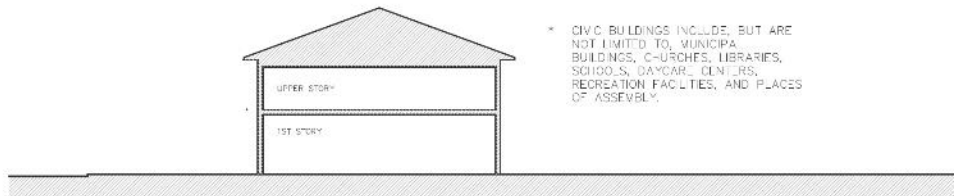

* CIVIC BUILDINGS INCLUDE, BUT ARE NOT LIMITED TO, MUNICIPAL BUILDINGS, CHURCHES, LIBRARIES, SCHOOLS, DAYCARE, CLINICS, RECREATION FACILITIES, AND PLACES OF ASSEMBLY.

* BUILDING PLACEMENT REQUIREMENTS FOR CIVIC BUILDINGS VARY BY SITE. IN GENERAL, CIVIC BUILDINGS SHOULD BE SITED IN LOCATIONS OF PARTICULAR GEOMETRIC IMPORTANCE, SUCH AS ANCHORING A MAJOR PUBLIC SPACE, OR TERMINATING A STREET VISTA.

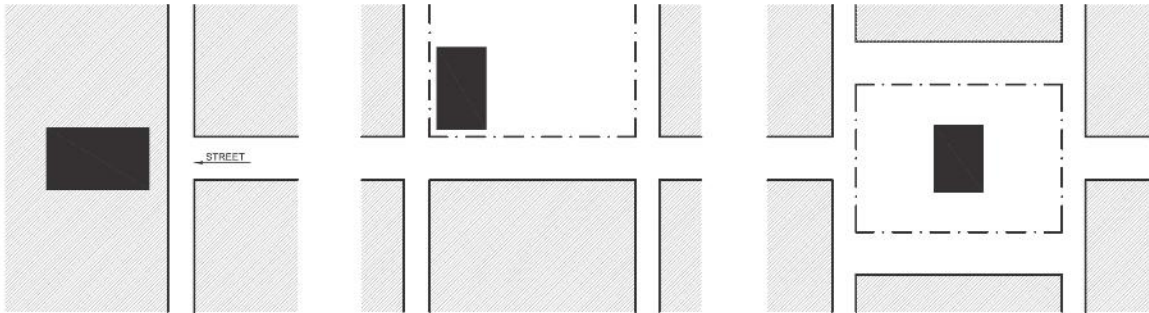

* THE CIVIC BUILDING TERMINATES THE VIEW OF THIS STREET.

* THE CIVIC BUILDING ANCHORS THE GREEN AT A PROMINENT CORNER.

* THE CIVIC BUILDING ANCHORS THE SPACE FROM WITHIN THE GREEN.

Each building on a Civic Building Lot must have an entrance facing a street or public open space. Parking shall be located to the side or rear of the building

Blocks:

Blocks may not exceed 400 feet in length and 200 feet in width, including alleys that may bisect the block. This shall be measured from street right-of-way to street right-of-way.

DRAFT 06.21.2021

8. Live/Work Building WVR-2(LW-WVR-2)

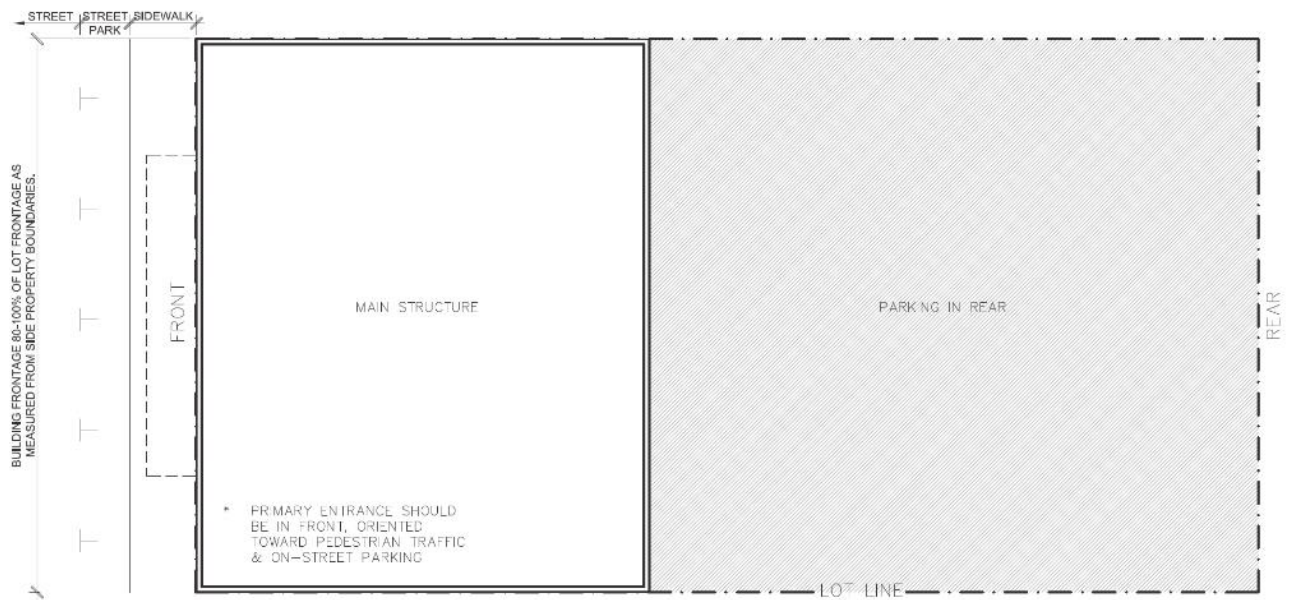
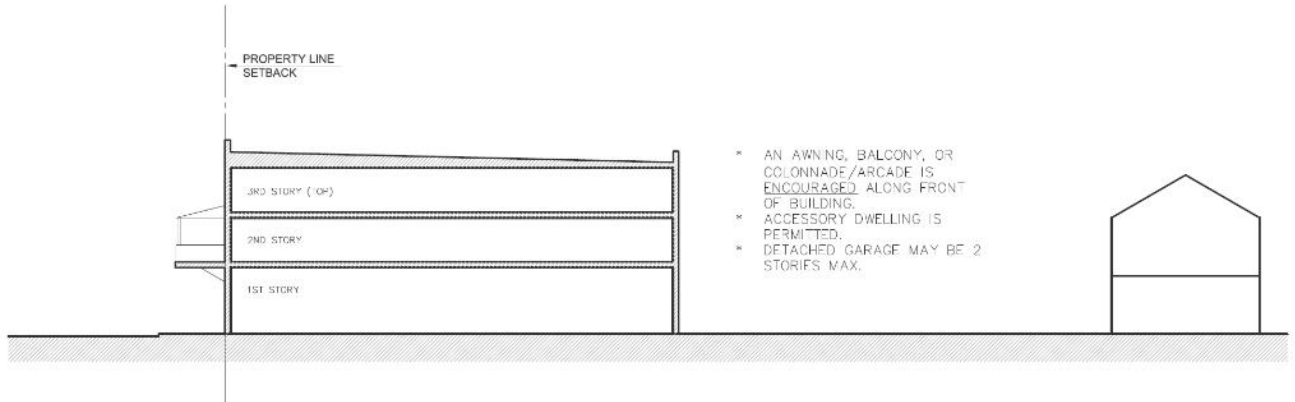

BUILDING PLACEMENT

Off-street parking for Live/Work Building lots shall be located behind or to the side of the main structure(s). No parking shall be located between the primary façade, or façade portion, closest to the street, and the street.

The building's primary orientation shall be toward the street rather than the parking areas. The primary building entrances shall be visible and directly accessible from a street.

DRAFT 06.21.2021

Section 3.24.07. – Allowable Street Types in the Wimauma Village Residential Neighborhood

- Boulevard
- Multimodal Avenue
- Neighborhood Street
- Greenway/Trail

Streets internal to the project shall be developed in accordance with at least two of the above-listed street types. Should the project connect to an existing community with an existing street developed in accordance with any of the above-listed street types, the same street type shall be provided within the subject community. Should a change in street type between an existing street type in an adjacent community and in the subject community be proposed, it shall be evaluated at the time of rezoning to determine if the street type change is appropriate.

Section 3.24.08. – Streetscape Standards for the Wimauma Village Residential Neighborhood

Definition of zones within cross sections.

1. Frontage Zone. The area adjacent to properties, such as building entrances, front yards, stoops, window shopping area, vending, café seating, and building-related utilities. This area may be part of the public right-of-way, or private, if a building setback is present.
2. Pedestrian Clearway Zone. The most important area of the street for safe, accessible, and efficient movement of pedestrians. The width depends on the street context. The minimum will be higher on streets with greater pedestrian activities. An adequate pedestrian clearway is most important in sidewalk design.
3. Furnishing and Planting Zone. This zone in the boulevard provides space for a wide range of street elements such as trees, other plantings, litter and recycling bins, benches, streetlights, and bicycle racks.
4. Edge Zone. The space behind the curb that acts as a buffer between moving/parked vehicles and the other sidewalk/boulevard functions. May accommodate signposts, parking machines, decorative pavers, and garbage set out.

Street Type Cross-Sections

1. Boulevard

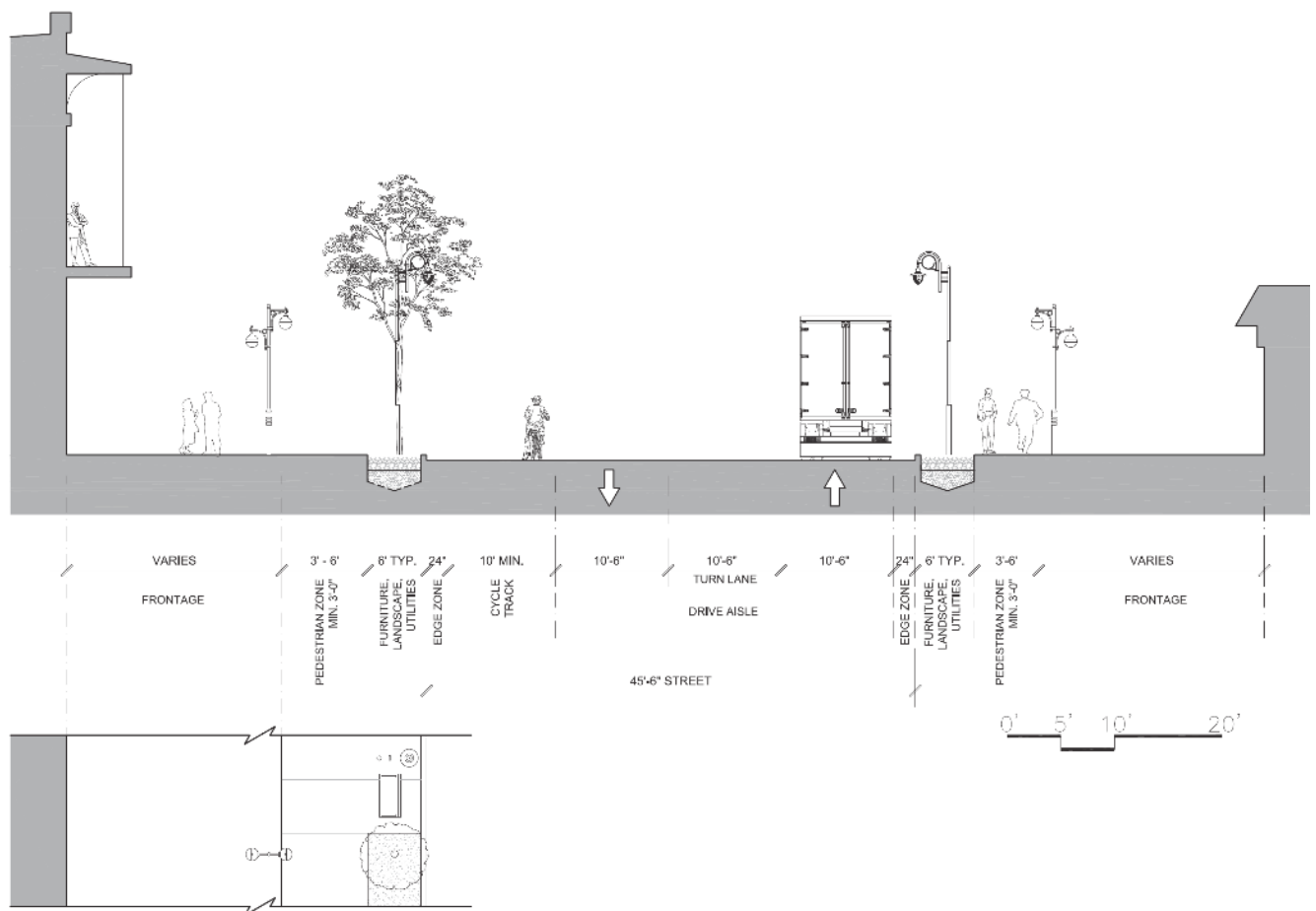

*Decorative street lighting should be installed in the Furnishing Zone, or within the area between the Pedestrian Zone to the Edge Zone

*Street trees are encouraged at a spacing of 25 feet to 30 feet on center.

*Planted buffers are the preferred protection or separation for bicycle lanes within the roadway.

*Utilities are encouraged to be installed underground.

2. Multimodal Avenue

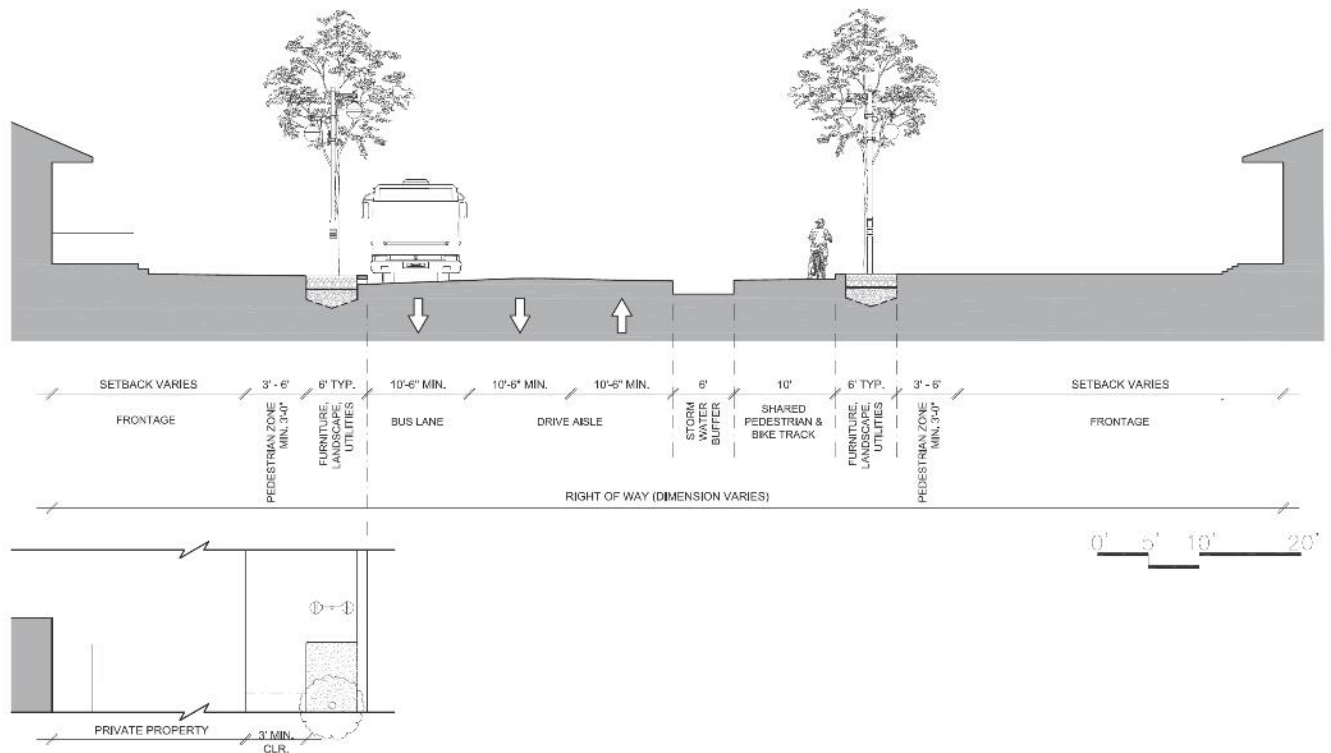

*Decorative street lighting should be installed in the Furnishing Zone, or within the area between the Pedestrian Zone to the Edge Zone

*Street trees are encouraged at a spacing of 25 feet to 30 feet on center.

*Planted buffers are the preferred protection or separation for bicycle lanes within the roadway.

*Utilities are encouraged to be installed underground.

* Stormwater refers to low impact stormwater collection that may serve as buffering between the roadway and multimodal trails/bicycle tracks.

3. Neighborhood Street

NEIGHBORHOOD

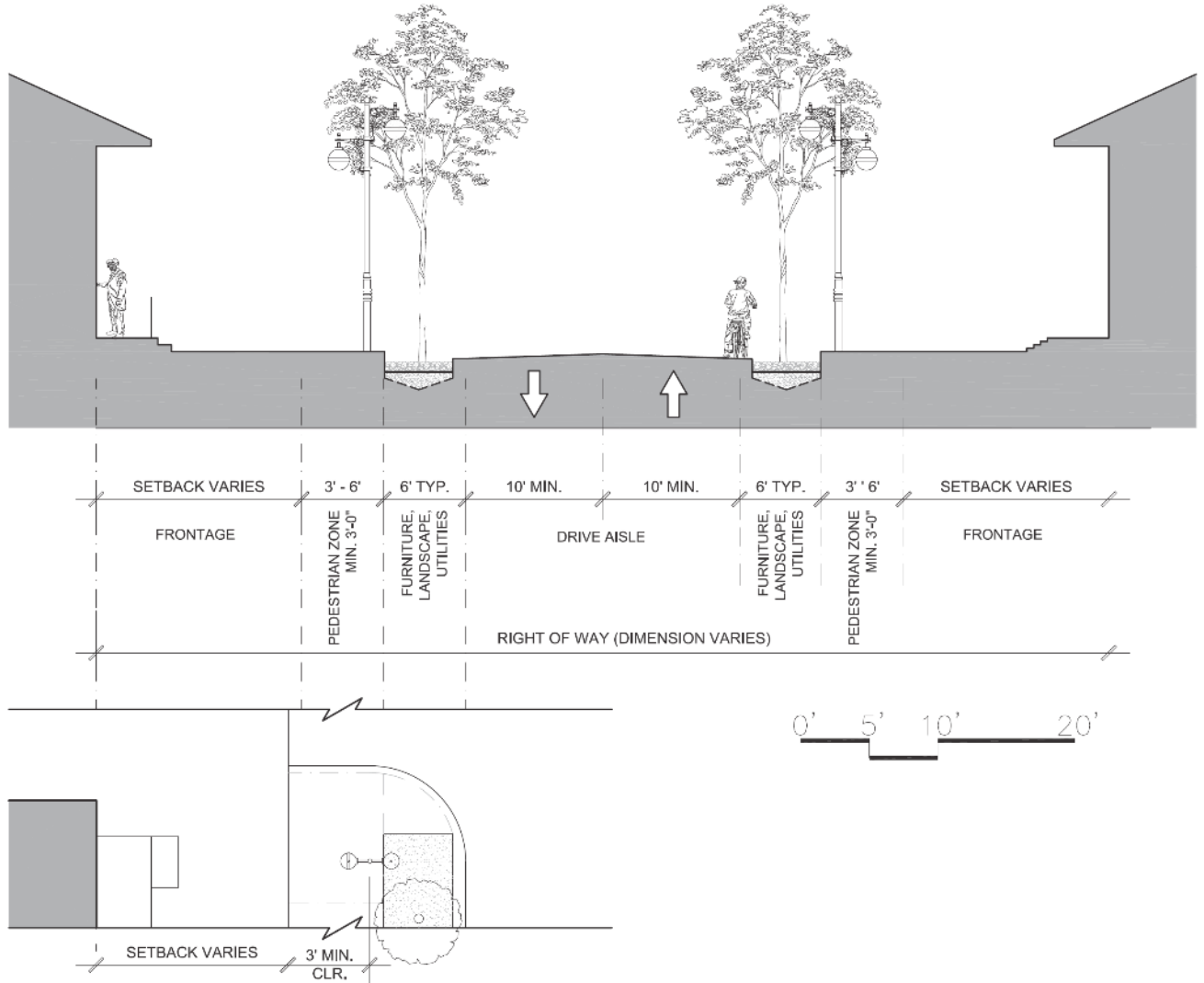

*Decorative street lighting should be installed in the Furnishing Zone, or within the area between the Pedestrian Zone to the Edge Zone

*Street trees are encouraged at a spacing of 25 feet to 30 feet on center.

*Utilities are encouraged to be installed underground.

4. Greenways

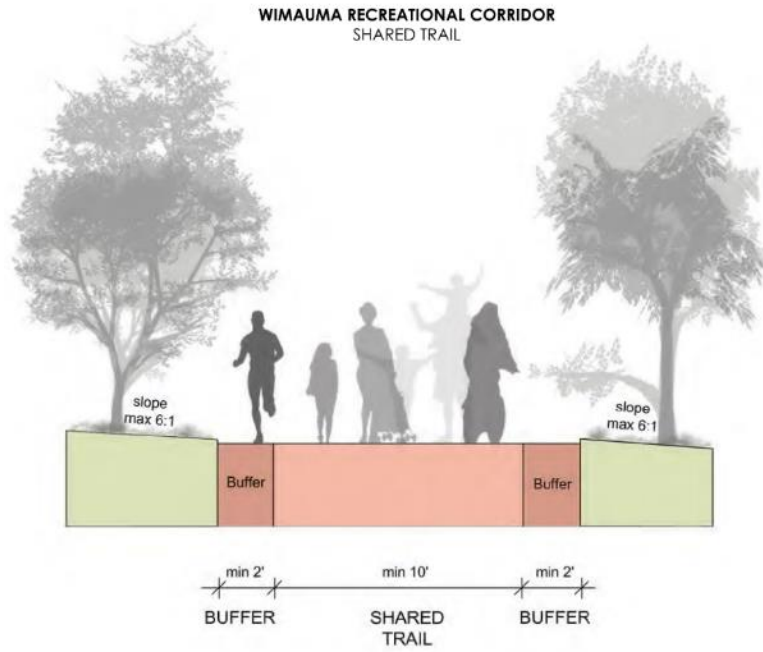

DRAFT 06.21.2021

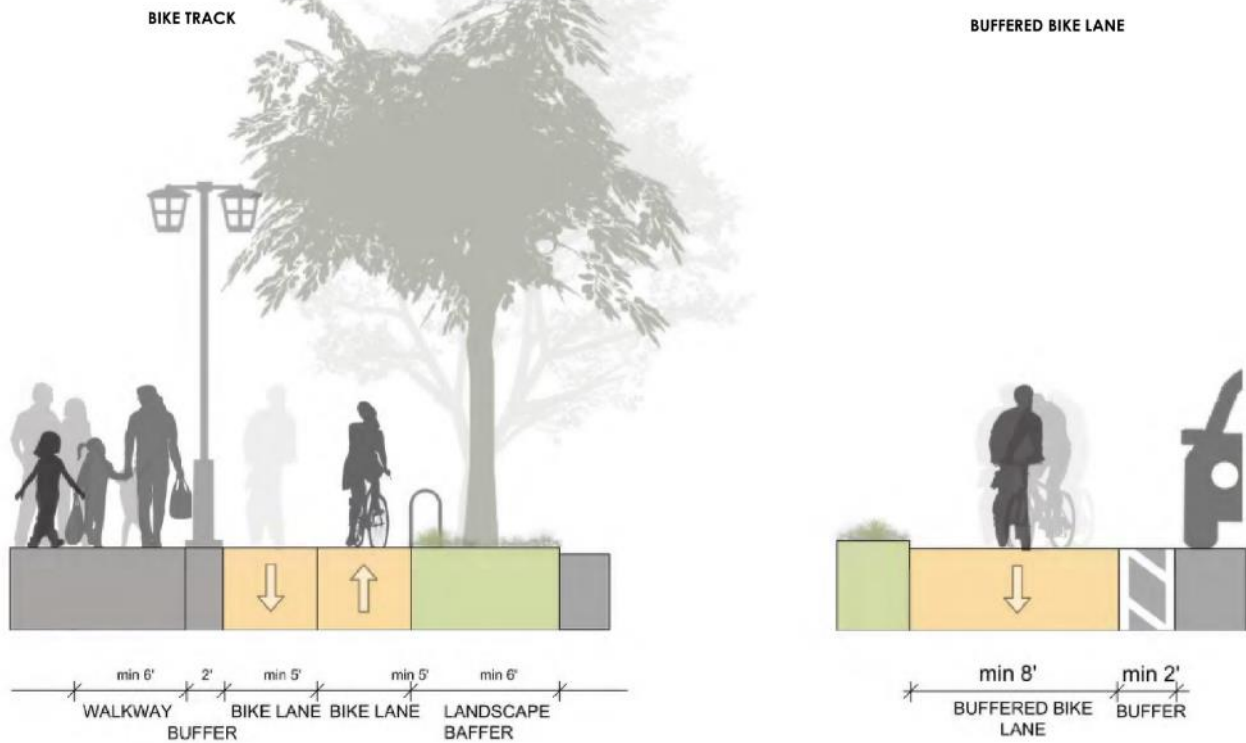

Section 3.24.09. – Mobility and Street Network Design

New streets shall connect with existing streets adjacent to the project should the adjacent street have provided an opportunity for connection.

Paved stub-outs shall be provided to accommodate future street connections when adjacent to vacant land or land which could be redeveloped for residential. Approximately every 1,320 feet, a street connection shall be provided. Exceptions to these requirements shall be allowed where environmental features prohibit connections.

A minimum 80% of the internal roadways shall be constructed in a manner to ensure that both ends of the roadway terminate with another roadway.

All streets must be publicly dedicated. Private streets and closed or gated streets are prohibited.

In addition to its network of streets, each PD shall also include a network of trails or greenways along streets and/or the site perimeter which are publicly accessible connecting urban, recreational, academic, rural locations, and existing trail networks. Trails shall be provided along the Wimauma Greenway Trail, or on the TECO easement with approval.

DRAFT 06.21.2021

Section 3.24.10. - Community Benefits Requirements

Community benefits and services shall support the needs of the community within the WVR-2 and the Wimauma Community Plan area consistent with Comprehensive Plan Policy 48.5 and Section 3.24.04 of this Part.

1. To encourage public benefits, projects may receive a density increase above 1 unit per 5 gross acres (unless otherwise specified by existing zoning) up to a total of 2 units per gross acre.

At least one benefit shall be offered for developments less than 25 acres.

At least two benefits shall be offered for developments less than 50 acres but equal to or greater than 25.

At least three benefits shall be offered for developments less than 100 acres but equal to or greater than 50.

At least four benefits shall be offered for developments less than 160 acres but equal to or greater than 100.

At least five benefits shall be offered for developments less than 320 acres but equal to or greater than 160.

At least six benefits shall be offered for developments greater than 320 acres.

2. New development shall include community benefit requirements to provide services to residents, which can be supported on-site or off-site per Table 12.1.

A. On-site community benefits or services shall be encouraged. Agricultural businesses such as organic farming, alternative energy production, community gardens, and farmers markets shall be encouraged. If on-site benefits and services are provided, they shall be located together to form a single node on the periphery of the neighborhood if adjacent to a collector or arterial roadway, or at the center of a neighborhood connected to the surrounding neighborhood by streets and pedestrian facilities. Residential support uses (childcare centers, adult care centers, churches, etc.) shall be located within and/or adjacent to the neighborhood center(s), except for community gardens or farms, or in a neighborhood center within the neighborhood.

3. All capital improvement costs associated with the provision of public facilities and services as determined by the appropriate regulatory agency or public service provider, including, but not limited to, public water, wastewater, fire, police, schools (with necessary transportation infrastructure to support a school use), parks, and libraries shall be the responsibility of the developer and not the responsibility of Hillsborough County.

DRAFT 06.21.2021

Table 12.1

Community Benefits	
	Proposed villages including (50) fifty or more residential units shall conduct at least one public meeting and shall notify all registered neighborhood groups within the Community Planning Area as defined within the Livable Communities Element to discuss the utilization of Community Benefit Options. This meeting shall occur within the defined Community Plan boundary and occur at least one month prior to a scheduled public hearing.
Tier 1: Community Benefits Priority List (For projects greater than 50 acres but less than or equal to 100 acres, at least one community benefit must be provided from Tier 1. For projects greater than 100 acres, at least two community benefits must be provided from Tier 1).	
1	Include combination of six (6) different Building Form types - no less than 10 percent and no more than 60 percent should be provided of one Lot and Building Form type per Section 3.24.05. The proposal of two Standard House Lot and Building Form types at two different lot sizes, lot widths and/or development standards shall be permitted to count for a maximum of two of the six different Lot and Building Form types. For all other Lot and Building Form types, multiple lot sizes, widths, or development standards proposals of the same Lot and Building Form type shall only count as one of the six required Lot and Building Form types. **
2	Construct multi-use trail adjacent to the TECO easement (as agreed during PD process), consistent with Hillsborough County Trails Master Plan and the Wimauma Community Plan or Construct at least two connections to an adjacent County trail system. Within the project, the connections must be at least 12 feet in width and be at least a half mile in length within the project. If relevant, construct trail as part of Wimauma Community Plan or connect to other trails found in the Long-Range Transportation Plan.**
3	Mobility Fee Alternative Satisfaction Agreement (MFASA), in which the developer has the option to construct a mobility improvement that would be counted toward the required mobility fee in accordance with Article III in Chapter 40 of the Hillsborough County Code of Ordinances.
4	Land dedication: public parks (per Hillsborough County Code of Ordinances Part A Section C, civic or community uses such as community gardens, farms in addition to design rules (when not used for these purposes, must be open to the public – as agreed during PD process). At least 5 acres must be provided. Benefit is in addition to the minimum Open Space requirement per Section 3.24.04. ***
5	Land dedication and connecting infrastructure (water, sewer and transportation infrastructure for internal site improvements including but not limited to roads, sidewalks, and trails) to Hillsborough County Public Schools for school purposes (if approved by Hillsborough County Public Schools and Hillsborough County). This Community Benefit requires completion of the school siting process as outlined in the Interlocal Agreement for School Facilities Planning, Siting and Concurrency.

DRAFT 06.21.2021

6	Construct on-site non-residential uses within the required Neighborhood Center acreage at 42 sq. ft. per housing unit utilizing 30 percent of the proposed units or 3,000 sq. ft. whichever is larger. Non-enclosed uses shall contribute a maximum of 37.5%.
Tier 2	
7	Transfer of Development Rights: Transfer a minimum of 10% of the base density of total PD units per acre to the Receiving Zone in Wimauma Downtown per Sec. 3.24.11. and/or other TDR receiving area as defined by Hillsborough County
8	Land dedication for ELAPP (approved by Hillsborough County) at a minimum of 10% of total site. Benefit is in addition to the minimum Open Space requirement per Section 3.24.04. ***
9	Project site built using National Green Building Standard practices or other green building program approved by the County.
10	Construct new non-residential use in the downtown Main Street Core or Downtown East. The requirement of 42 sq ft per household for the required non-residential uses shall be based on 30% total unit count or 3,000 sq ft whichever is larger.
11	Internal recreation and open space shall exceed regulation per Section 3.24.04 by no less than 25%. **
12	Dedicate additional on-site land for neighborhood center, to promote residential support uses (at least 1 acre). Dedicated land shall be located in a Neighborhood Center****
13	Benefit shall directly or indirectly make a contribution towards furthering a defined goal within the Wimauma Community Plan as exhibited in the Livable Communities Element. This benefit may include economic development, transit, affordable housing, internet access or other contributions.****
<p>*Projects using this community benefit shall require that at least 50% of on-site or off-site square footage shall receive a Certificate of Occupancy prior to the final plat approval of more than 75% of the residential units. 100% of the on-site or off-site square footage shall receive a Certificate of Occupancy prior to the final plat approval of more than 90% of the residential units.</p> <p>**Compliance with these community benefits shall be demonstrated on the general site plan of the rezoning application.</p> <p>***These community benefits shall require written agreement/acceptance by the receiving entity of the dedicated land to provide assurances at the time of rezoning the benefit will be provided. Additionally, documentation of the conveyance of that land to the receiving entity is required prior to final plat approval.</p> <p>****Benefit may be used more than once if offering multiple benefits satisfying or furthering multiple Community goals.</p>	

Section 3.24.11. – Transfer of Development Rights

The development rights attached to a parcel of land can sometimes be transferred to other parcels. The TDR Element encourages the transfer of density for several purposes: to move potential development to certain locations inside the USA; to encourage continued use of land for rural and open space purposes by transferring potential density off the land which maintains

DRAFT 06.21.2021

value of the sending zone; and to allow the accumulation of sufficient development rights to support downtown development.

1. Allow for the transfer of up to 2 dwelling units per gross acre (DU/GA) densities between 2 separately owned or commonly held properties, whether or not they are contiguous to each other. The designated sending area shall be inside the limits of the Wimauma Village Residential-2 category and other rural areas outside of USA.

A. Downtown Receiving Zone: The designated receiving areas shall be inside the Wimauma Village Residential-2 category, inside the Urban Service Area portion of the Wimauma Village Plan, or in the priority Wimauma Downtown Receiving Zone.

2. To support housing growth in the Wimauma Downtown and preserve rural areas within the WVR-2, the exchange ratio for transfer of dwelling units into the priority receiving zone of the Wimauma Downtown Main Street Core will be 2 DU/GA to 4 DU/GA, a ratio of 1:2 (except in WVR-2 to WVR-2 transfers, the ratio is 1:1). No property shall be left with less development rights than there are existing dwellings on said properties, or less than 1 dwelling unit development for any parcel which would otherwise be eligible for a dwelling unit. TDR tracking shall be via file-permanent deed restriction to be in the form of a conservation easement consistent with Section 704.06, Florida Statutes, to be granted by the owner of the sending parcel and accepted by the Board of County Commissioners and recorded in the official public records prior to preliminary plat approval for the receiving area.

3. To support the Main Street Core and economic development, stacking of TDR and Affordable Housing Density Bonuses will be allowed and encouraged in the Downtown Receiving Zone. Stacking of TDR and Affordable Housing Density Bonuses shall not be permitted in WVR-2 to WVR-2 transfers.